

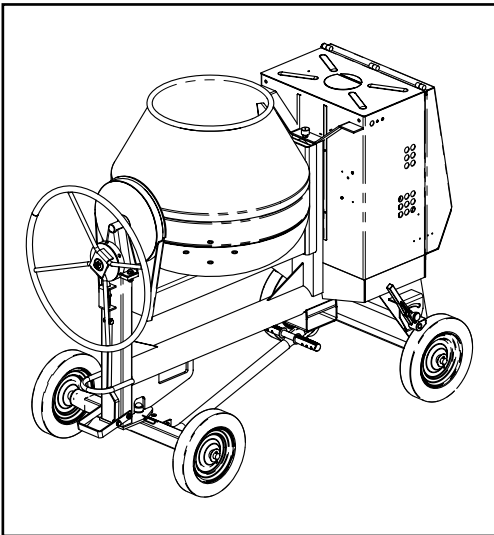

PREMIER

XT



- Spare Parts Book

16

EC DECLARATION OF CONFORMITY / DECLARATION CE DE CONFORMITE / DECLARACIÓN DE CONFORMIDAD CE / DECLARAÇÃO CE DE CONFORMIDADE / EG-VERKLARING VAN OVEREENSTEMMING / EF OVERENSSTEMMELSESERKLÆRING

(GB) We, **Belle Group Sheen UK, Sheen, Nr. Buxton, Derbyshire, SK17 0EU, GB**, hereby certify that if the product described within this certificate is bought from an authorised Belle Group dealer within the EEC, it conforms to the following EEC directives: 98/37/EC (This directive is a consolidation of the original machinery directive 89/392/EEC), Electromagnetic Compatibility Directive 89/336/EEC (as amended by 92/31/EEC & 93/68 EEC). The low voltage directive 73/23/EEC, EN 292 Safety of machinery and associated harmonised standards, where applicable. Noise emissions conform to directive 2000/14/EC Annex VI, for machines under article 12 the notified body is **AV Technology Limited, AVTECH house, Birdhall Lane, Cheadle Heath, Stockport, Cheshire, SK3 0XU, GB**.

(F) Nous soussignons, **Belle Group Sheen UK, Sheen, Nr. Buxton, Derbyshire, SK17 0EU, GB**, certifions que si le produit décrit dans ce certificat est acheté chez un distributeur autorisé Belle Group au sein de la CEE, il est conforme aux normes CEE ci-après: 98/37/CE (Cette norme est une codification des normes de la machine d'origine 89/392/CEE), Norme compatible pour l'électromagnétisme 89/336/CEE (modifié par 92/31/CEE et 93/68/CEE). Caractéristiques basse tension 73/23/CEE, EN 292, Norme de sécurité des machines et des critères associés et configurés, si applicable. Les émissions de bruit sont conformes à la directive 2000/14/EC Annexe VI pour machines, article 12, l'objet mentionné est **AV Technology Limited, AVTECH House, Birdhall Lane, Cheadle Heath, Stockport, Cheshire, SK3 0XU, GB**.

(E) La Sociedad, **Belle Group Sheen UK, Sheen, Nr. Buxton, Derbyshire, SK 17 OEU, GB**, por el presente documento certifica que si el producto descrito en este certificado es comprado a un distribuidor autorizado de Belle Group en la CEE, este es conforme a las siguientes directivas: 98/37/CE de la CEE (Esta directiva consolida la directiva inicial sobre maquinaria 89/392/CEE), Directiva 89/336 CEE sobre Compatibilidad Electromagnética (según enmiendas 92/31/CEE y 93/68 CEE), Directiva sobre Bajo Voltaje 73/23/CEE, EN 292 de Seguridad de Maquinaria y Niveles armonizados estándares asociados donde sean aplicables. Emisión de Ruidos conforme a la Directiva 2000/14/CE Anexo VI para máquinas bajo artículo 12 la mencionada unidad está **AV Technology Limited, AVTECH House, Birdhall Lane, Cheadle Heath, Stockport, Cheshire, SK3 0XU, GB**.

(P) O signatário, **Belle Group Sheen UK, Sheen, Nr. Buxton, Derbyshire, SK 0EU, GB**, pelo presente, declara que se o produto descrito neste certificado foi adquirido a um distribuidor autorizado do Belle Group em qualquer país da UE, está em conformidade com o estabelecido nas seguintes directivas comunitárias: 98/37/EC (esta directiva é uma consolidação da directiva de maquinaria original 89/392/EEC), Directiva de Compatibilidade Electromagnética 89/336/EEC (conforme corrigido pelas 92/31/EEC & 93/68 EEC). A directiva de baixa voltagem 73/23/EEC, EN 292 Segurança da maquinaria e às normas harmonizadas afins se aplicáveis. As emissões de ruído respeitam e estão dentro das directivas para máquinas 2000/14/EC Anexo VI, artigo 12, sendo o organismo notificado **AV Technology Limited, AVTECH house, Birdhall Lane, Cheadle Heath, Stockport, Cheshire, SK3 0XU, GB**.

(NL) Ondergetekende, **Belle Group Sheen UK, Sheen, Nr. Buxton, Derbyshire, SK17 OEU, GB**, verklaren hierbij dat als het product zoals beschreven in dit certificaat is gekocht van een erkende Belle Group dealer binnen de EEG, het voldoet aan de volgende EEG richtlijnen: 98/37/EC (Deze richtlijn is een opvolger van de originele Machinerichtlijn 89/392/EEG), Electromagnetische Compatibiliteit Richtlijn 89/336/EEG (geamendeerd door 92/31/EEG & 93/68 EEG). De Laagspannings Richtlijn 72/23/EEG, EN 292 Veiligheid van Machines en hieraan gekoppelde geharmoniseerde Standaarden, waar deze van toepassing is. Rumoeer emissies passen voor richtlijn EC Zijgebouw VI, voor toestel onder stuk 12 naar de notified troep zit **AV Technology Limited, AVTECH house, Birdhall Lane, Cheadle Heath, Stockport, Cheshire, SK3 0XU, GB**

(DK) Vi, **Belle Group Sheen UK, Sheen, Nr. Buxton, Derbyshire, SK17 0EU, GB**, erklærer hermed, at hvis det i dette certifikat beskrevne produkt er købt hos en autoriseret Belle Group forhandler i EU, er det i overensstemmelse med følgende EØF-direktiver: 98/37/EF, 73/23/EØF (som ændret ved 93/68/EØF), 89/336/EØF (som ændret ved 92/31/EØF), 93/68/EØF og tilknyttede, harmoniserede standarder, hvor relevant. Støjniveauet er i overensstemmelse med direktiv 2000/14/EF, bilag VI gældende for maskiner under paragraf 12. Det bemyndigede organ er **AV Technology Limited, AVTECH house, Birdhall Lane, Cheadle Heath, Stockport, Cheshire, SK3 0XU, Storbritanien**.

PRODUCT TYPE	TYPE DE PRODUIT	TIPO DE PRODUCTO	TIPO DE PRODUTO:
MODEL	MODELE.....	MODELO	MODELO:.....
SERIAL No.....	N° DE SERIE	N° DE SERIE	NO. DE SÉRIE:
DATE OF MANUFACTURE...	DATE DE FABRICATION.....	FECHA DE FABRICACIÓN....	DATA DE FABRIC.....
SOUND POWER LEVEL..... MEASURED (GUARANTEED):	NIVEAU DE PUISSANCE SONORE MESUREE (GARANTIE)	NIVEL DE POTENCIA ACÚSTICA MEDIDO (GARANTIZADO)	NIVEL DE POTÊNCIA DE SOM MEDIDO (GARANTIDO)

PRODUCTTYPE.....	PRODUKTTYPE.....
MODEL	MODEL
SERIENUMMER	SERIENR.
FABRICAGEDATUM	FREMSTILLINGSDATO.....
GEMETEN	LYDEFFEKTNIVEAU
GELUIDSSTERKTENIVEAU (GEGARANDEERD)	MÅLT (GARANTERET)

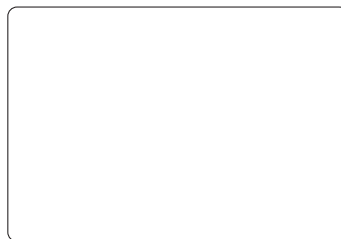

Signed by:
Signature:
Medido por:
Assinado por:
Getekend door:
Uunderskrevet af:

Ray Neilson

Managing Director - On behalf of BELLE GROUP (SHEEN) UK.
Le Directeur Général - Pour le compte de la SOCIETE BELLE GROUP (SHEEN) UK.
Director Gerente - En nombre de BELLE GROUP (SHEEN) UK.
Director-Geral - Em nome de BELLE GROUP (SHEEN) UK.
Algemeen Directeur - Namens BELLE GROUP (SHEEN) UK.
Administrerende direktør - På vegne af BELLE GROUP (SHEEN) UK.



Engine Warranty

The engines installed in the Belle Premier XT range of mixers carry a 12 month warranty. Any problems encountered with the engine, during the warranty period should be dealt with by the relevant approved engine dealer, nearest to yourself.

If you require the name of your nearest approved engine dealer, a full listing is available on request from Belle.

Serial Numbers

ATTENTION! Make a note of the serial numbers of your machine and always quote them in any communication with a Belle Group Dealer.

MACHINE SERIAL NUMBER

ENGINE / MOTOR SERIAL NUMBER



Introduction

Congratulations on the purchase of this quality concrete mixer from the Belle Group range.

This machine is manufactured to conform to the EEC directives currently in force and is issued with a declaration of conformity and therefore displays the CE mark, applicable in territories where they are enforced.

Read this manual carefully, observing all operating and safety instructions before, during and after using your machine. Maintain your machine in good working order.

When maintaining this machine only the manufacturer's original spare parts may be used. The user will lose any possible claims if replacement parts used are other than the makers original spare parts.

Retain this manual with your machine for future reference.

SAFETY AND ACCIDENT PROTECTION

Operating Instructions :

All persons who apply, assemble, operate, start, control, maintain or repair this machine must read and understand these operating instructions.

Owner Responsibility :

The owner must ensure that only qualified persons operate, maintain, or repair this machine.

Storage :

When not in use, store in a dry, locked place. Keep away from children.

Operation for the Intended Purpose :

Mixers are intended for the production of concrete, mortar and plaster. The mixer must be used for its intended purposes and is not suitable for the mixing of flammable or explosive substances. The mixers must not be used in an explosive atmosphere.

MAINTENANCE AND REPAIRS

Only authorised dealers should repair the mixer, and within the requirements of the CE mark (where applicable), where no deviation to the original specification must take place.



WARNING

Any maintenance and repairs carried out, to any of the electric motors components must be undertaken by a qualified electrician.

REPLACEMENT PARTS

Contact your nearest Belle Group dealer. When ordering replacement parts, please quote the product type, serial number & engine/motor model. Detail the part required in conjunction with the parts list provided, indicating the Page Number, Item Number and quantity required.

	Page number
Engine Warranty	4
Introduction	4
Warning Symbols	5
Plug Wiring	5
Safety Instructions	6
Transportation	7
Mixing Positions	7
Mixing Hints	8
Functional Controls	9
Operating Instructions - Electric Motors	10
Operating Instructions - Yanmar L48	11
Operating Instructions - Lister Petter Build 10 & 32	11
Maintenance Instructions	12
Lister Petter 10 & 32 Checks & Maintenance schedule	13
Yanmar L48 Checks & Maintenance schedule	14
Technical Data	15

Belle Group reserves the right to change machine specification without prior notice or obligation.

Warning Symbols



WEAR EAR PROTECTION



FIRE AND EXPLOSIVE RISK

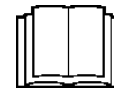

READ OPERATOR
MANUAL



WEAR EYE PROTECTION



WEAR PROTECTIVE
FOOTWEAR



LIFTING POINT

WARNING - IMPORTANT

The Premier range of mixers are intended for industrial use, the following plug types are supplied fitted to the product:

110V motor - 32 amp rated BS4343 plug type.

230V motor - 16 amp rated BS4343 plug type.

415V motor - 32 amp rated BS4343 plug type.

Reference the 230V version, if the plug supplied with your product does not suit the supply outlet you are connecting too, it should be removed and the appropriate plug fitted (3 pin BS1363 fused 13 amp for domestic household supplies).

Fitting a plug - **WARNING THIS PRODUCT MUST BE EARTHED**

IMPORTANT: The wires in the mains lead are coloured in accordance with the following code:

GREEN / YELLOW = EARTH, BLUE = NEUTRAL, BROWN = LIVE

The wire which is coloured Green and Yellow must be connected to the terminal in the plug marked E or coloured Green and Yellow. The wire which is coloured Brown must be connected to the terminal in the plug marked L or coloured Red. The wire which is coloured Blue must be connected to the terminal in the plug marked N or coloured Black.

Always ensure before connecting to the supply that the supply voltage is the same as the rated voltage marked on the motor.

READ THESE SAFETY INSTRUCTIONS

Please read and understand all running/safety instructions before operating this machine.

BEFORE STARTING THE MIXER

- Check that all guards are in position and correctly fitted.
- **DO NOT** wear loose clothing or jewellery that may become entangled in the workings of this machine.
- Suitable clothing as follows should meet relevant EEC/local safety standards: overalls, work boots, goggles, face mask, gloves and ear defenders etc.
- On electric powered mixers, ensure that any trailing cable is protected against damage and not liable to be tripped over or trapped underneath the mixer.
- **Belle strongly recommends the use of a Residual Current Device on 220/240v electrics.**
- Remove all packaging material before operating.

WHEN OPERATING THE MIXER

- Keep engine housing lid closed whilst it is mixing.
- Keep unauthorised persons away from mixing drum.
- Keep area around the mixer clear of obstructions which could cause persons to fall onto moving parts.
- Always ensure mixer is on level ground before mixing.
- Ensure rear wheel brakes are applied before operating the mixer.
- **DO** become familiar with the controls before operating this machine.
- **DO** ensure plenty of ventilation when running the diesel engines in a confined area.
- **DO** replace any worn/damaged warning decals.
- **DO** ensure the drum is rotating while emptying the mixer.
- **DO** always switch off and remove the plug from the socket if leaving the machine unattended.
- **DO NOT** transport this mixer when mixing.
- **BEWARE** of the danger zones.

EMERGENCY STOP

See Operating Instructions Section for details.

FIRE FIGHTING

If your mixer catches fire, turn off the electric supply.

Using a dry powder or CO2 fire extinguisher put out the fire. If the fire can not be put out, keep away and call the fire brigade.

If you are in any doubt about the safety condition of your machine, please consult your nearest Belle dealer or Belle direct.

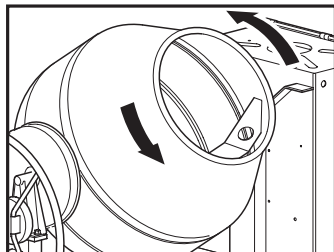

DRUM ROTATES ANTI-CLOCKWISE

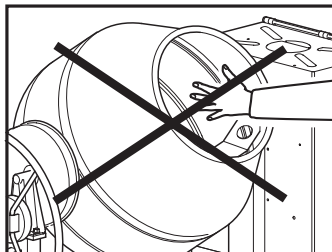

DO NOT PUT ANY PART OF YOUR BODY IN THE DRUM

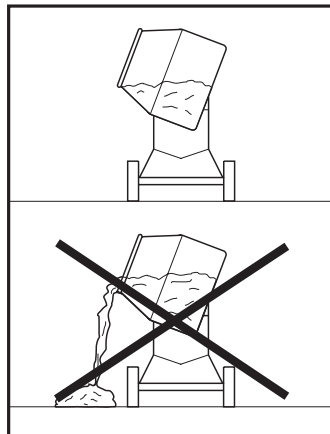

ALWAYS WORK WITHIN THE RATED CAPACITY

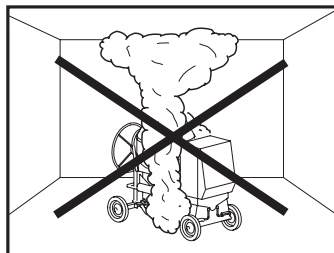

ALWAYS MIX IN WELL VENTILATED PLACES EXHAUST FUMES CAN KILL

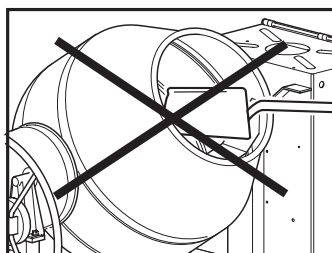

DO NOT PUT SHOVEL IN THE DRUM

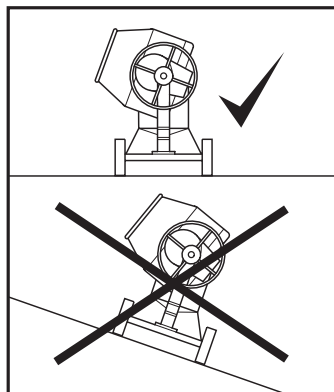

ALWAYS MIX ON LEVEL GROUND



DO NOT FILL WITH FUEL OR LUBRICATION OILS WHILST ENGINE IS RUNNING

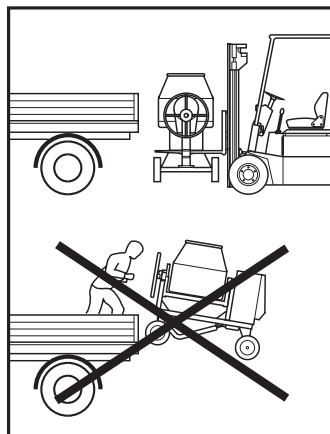

LOAD AND UNLOAD FROM THE TRANSPORT CORRECTLY
(See Transport Section in Manual)

LOADING BY FORK LIFT

- For normal site to site transporting, the usual method of loading into a pick-up truck or trailer should be used. A fork socket (Fig 3) is located beneath the main frame to enable the mixer to be loaded using a forklift (Fig 1).

LOADING BY CRANE

- To expose the lifting eye, turn the drum so it is facing down, (Fig 2).
- Ensure the lifting ropes are inspected to the current Health and Safety guidelines and are sufficient to carry the total weight of the mixer. See technical data. Ensure the lifting hook is correctly located prior to lifting the machine.
- **DO NOT** stand underneath the machine whilst it is being lifted.

TOWING

- These mixers are designed for on site towing only, maximum speed 5mph/8 kmh (Fig 4), for short periods of time.
- **DO NOT** tow on a public highway.

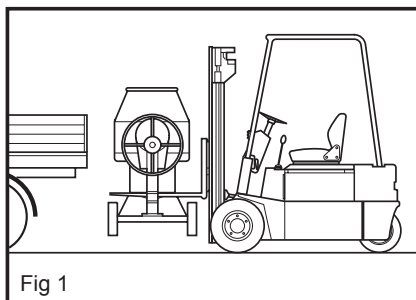

Fig 1

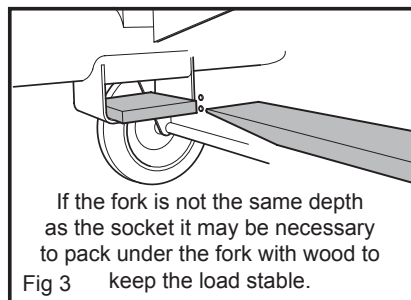

Fig 3 keep the load stable.

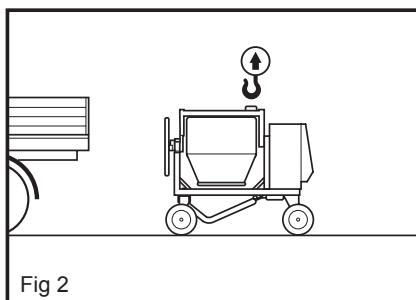

Fig 2

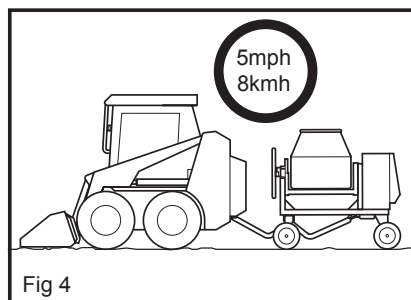

Fig 4

Mixing Positions

DRUM TILTING

The hand wheel gives an easy positive control of the drum which can be locked in the stored, mix, and discharge position.

The drum is locked in position by a self locating plunger which engages into the handwheel. To move the drum the locating plunger must be dis-engaged, this is done by pressing down on the footpedal (this is situated just above the pivoting front axle), the handwheel will now move freely allowing the re-positioning of the drum, to relock the drum in position, release the footpedal and rotate the handwheel until the self-locating locking plunger engages into the handwheel ring.

- **DO NOT** put your hand through the hand wheel.
- **ALWAYS** keep both hands on the hand wheel.

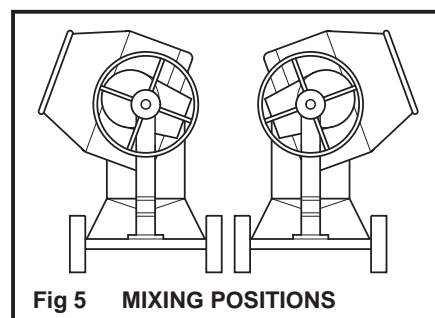

Fig 5 MIXING POSITIONS

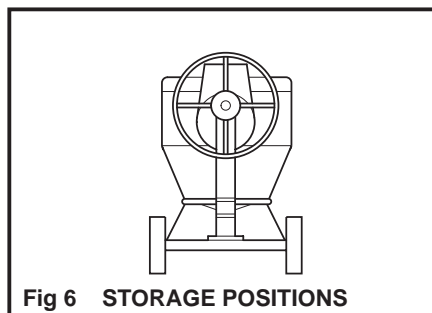

Fig 6 STORAGE POSITIONS

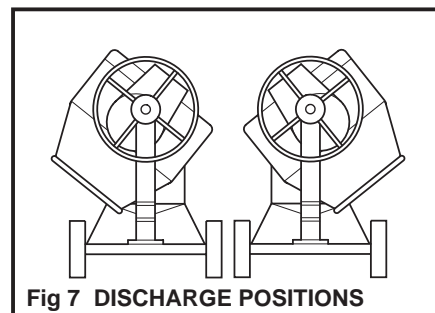

Fig 7 DISCHARGE POSITIONS



Mixing Hints

Mix Ratios

The correct mix ratio (cement:sand:stone) depends on the type of application; harder concrete requires more cement, rougher applications require more aggregate. The ratios given below are guidelines: best proportions may depend on the quality of sand/stone used.

First put in the water - around 7 litres (1½ gallons), using more or less depending on the type of mix required. Add some aggregate before adding cement, to avoid sticking. Work consistently to the ratio of ingredients for whatever type of concrete mix you are working to.

Getting A Good Mix

The approximate mixing time for concrete is 2-4 minutes from when all the material (including the water) has been added - over-mixing can reduce strength and cause segregation of the coarser aggregates.

Beware of low grade aggregates; these will only lead to trouble later on with sinking and frost spoiling the appearance of the pour. Also do not get the concrete mix too wet as this can reduce strength and make it less able to withstand weathering.

Looking After Your Mixer

Never throw material into the mixer - trickle it steadily over the rim or it will stick firmly to the back of the drum and can only be dislodged by stopping the mixer.

Keep your mixer clean - material left in the drum will harden, and attract more on each use until the mixer is useless.

Do not throw bricks into a mixer drum to clean it out. The best method is a mix of 1" (2½cm) gravel and clean water - use plenty of it, as this will do the job in half the time.

APPLICATIONS	QUANTITIES		
	CEMENT	SAND	STONE
MOST ORDINARY	1	2	4
FOUNDATIONS	1	3	6
ROUGH MASS CONCRETE	1	4	8
WATERTIGHT FLOORS, TANKS PITS ETC.	1	1.5	3

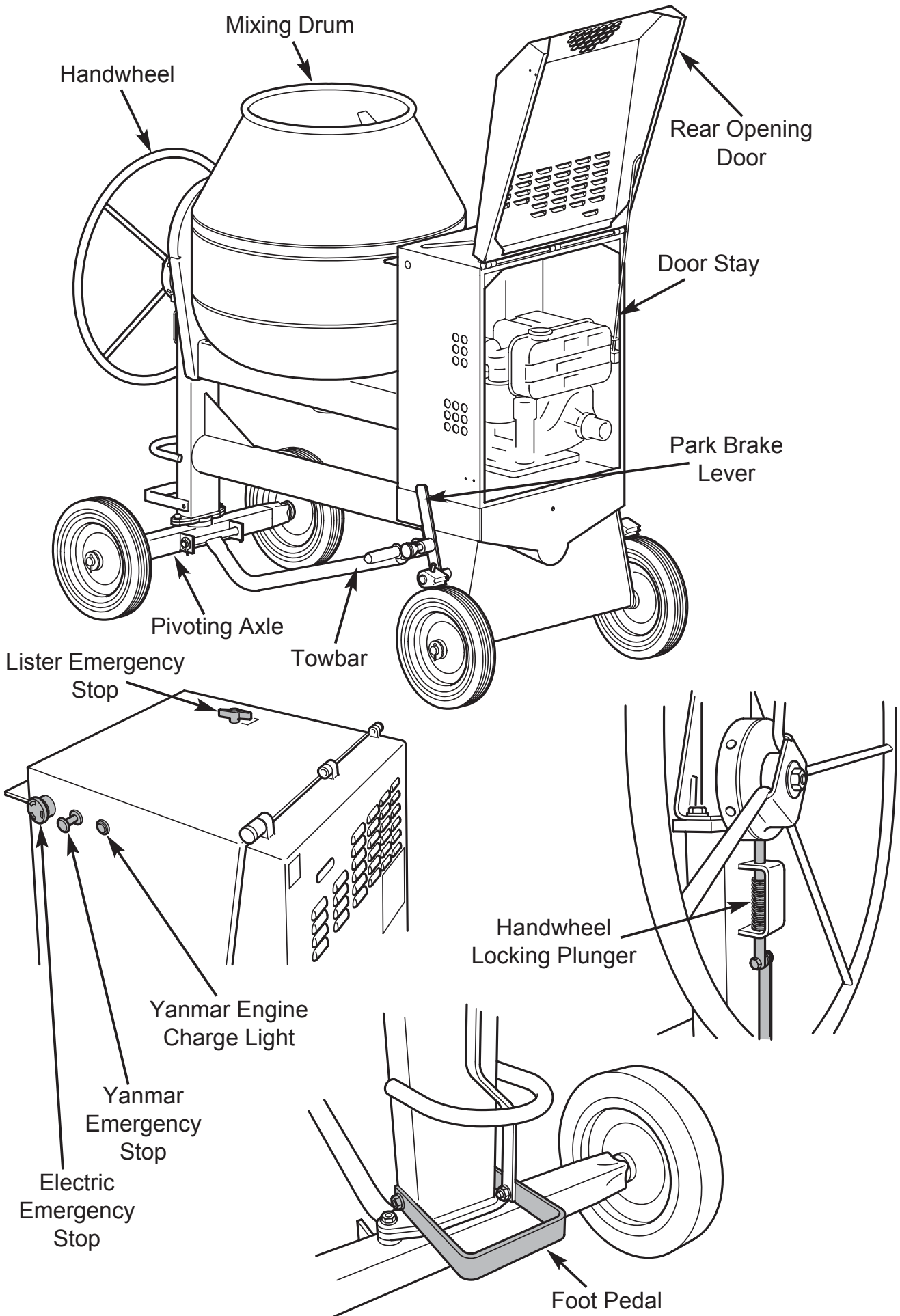

1. ELECTRIC MOTOR : VARIANTS

STOPPING

- 1.1 Depress RED Button (or on/off toggle switch if fitted to the Off position) to stop mixer (Fig B).

STARTING

- 1.2 Lift rear door.
 1.3 Feed supply cable out through the rear of the mixer and plug into power supply.
 1.4 Depress GREEN Button (or on/off toggle switch if fitted to the On position) to start mixer (Fig A).

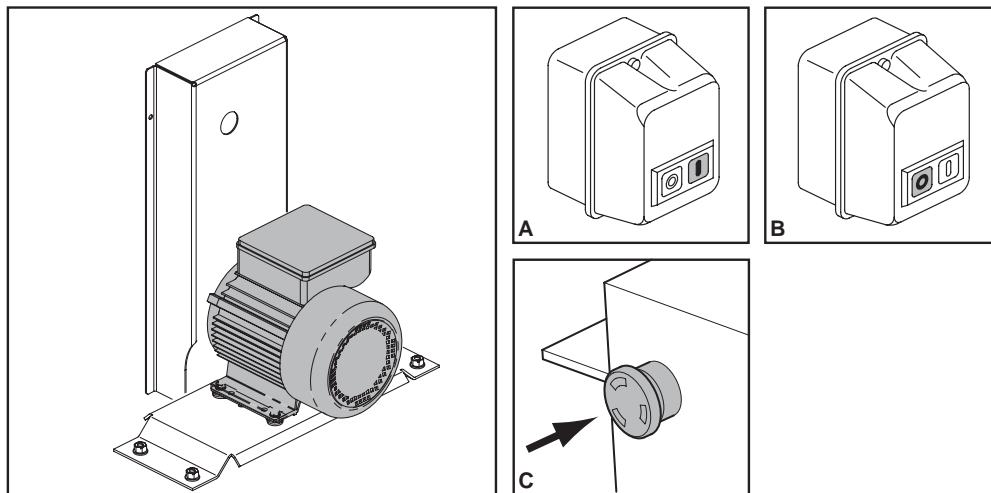

- Ensure supply cable is safely stored before moving mixer.
- Keep rear door shut when mixer is running

EMERGENCY STOP

- 1.5 Depress large RED Button, situated on top left hand side of power unit housing (Fig C).

- 110V & 415V (Brook Hansen) motor, Start / Stop using a control box situated on inside left of power unit housing.

2. YANMAR (ELECTRIC START)

STOPPING

- 2.1 Press Red Lever (Fig D).

- **Note:** Red indicator light glows when engine charging system fails.
- **Ensure that when machine is not in use that ignition is switched OFF, or battery failure may occur.**

EMERGENCY STOP

- 2.2 Pull the handle on the side of the power unit box to STOP the machine (Fig E).

COLD STARTING

- 2.3 Lift rear door.

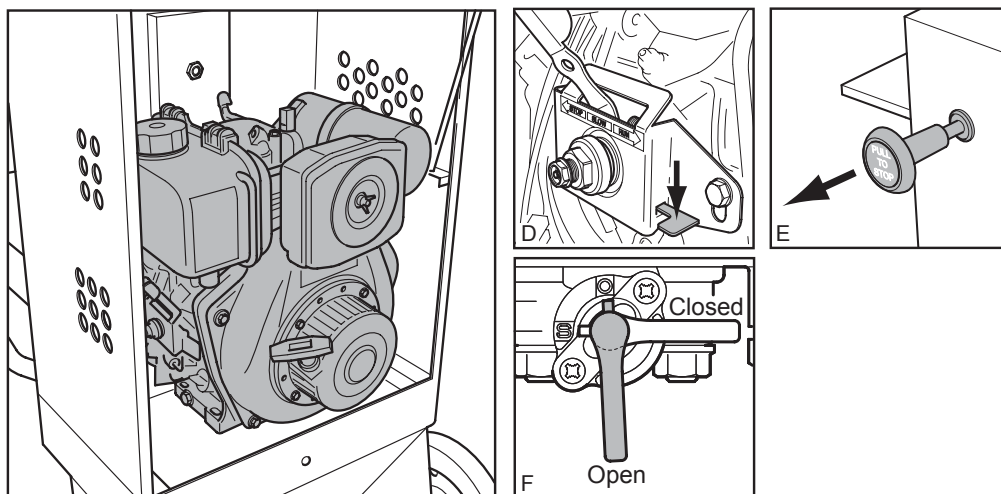

- Open fuel cock if fitted (Fig F).

- 2.4 In cold starting situations the engine requires 2cc of engine oil (10w-30) to be applied using oil applicator. The oil should be inserted into the engine by removing the rubber plug on the priming port, ensure the plug is replaced (Fig G).

- 2.5 Ensure the Emergency Stop Button is pushed in (Fig H).

- 2.6 Set the engine speed lever (situated on the left hand side of engine) to the run position (Fig I).

- 2.7 Turn ignition key clockwise until engine turns over, release key when engine starts. If engine fails to start, repeat process of cold start.

- **Note:** Once an attempt to start the engine has failed, before re-trying the key must be turned back to the OFF position.
- **DO NOT operate with rear door open.**

WARM STARTING

- 2.8 Repeat process above from 2.5.

3. YANMAR (RECOIL START) Back Up to Electric Start

STOPPING

3.9 Press red lever (Fig D).

EMERGENCY STOP

3.10 Pull the handle on the side of the power unit box to STOP the machine (Fig E).

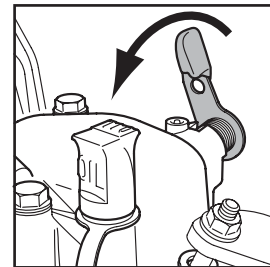
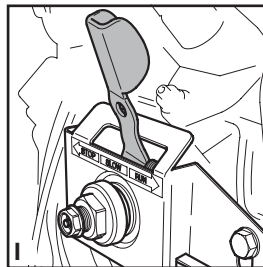
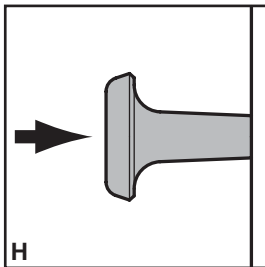
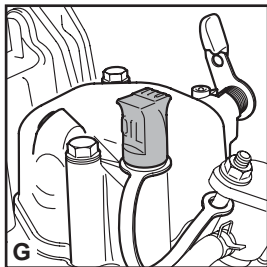

COLD STARTING

3.11 Lift rear door.

Open fuel cock if fitted (Fig F).

3.12 In cold starting situations the engine requires 2cc of engine oil (10w-30) to be applied using oil applicator. The oil should be inserted into the engine by removing the rubber plug on the priming port, ensure the plug is replaced (Fig G).

3.13 Ensure the Emergency Stop Button is pushed in (Fig H).

3.14 Set the engine speed lever (situated on the left hand side of engine) to the run position (Fig I).

3.15 Pull out the recoil starting handle to the point where you feel a strong resistance, then return back the install position. Push over the decompression lever (top right hand side of engine) this will return automatically when the recoil handle is pulled for the second time.

3.16 Apply both hands to the recoil starting handle and pull briskly, if engine does not start repeat from 3.15.

- DO NOT operate with rear door open.

WARM STARTING

3.17 Repeat process above from 3.14.

4. LISTER PETER : CRANK HANDLE START

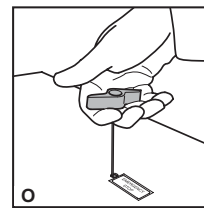
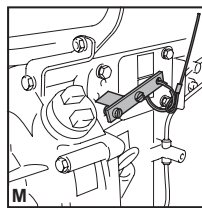
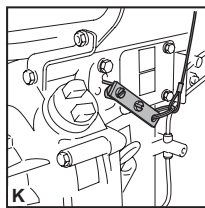
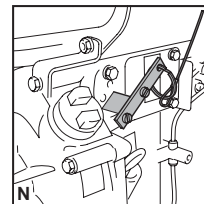
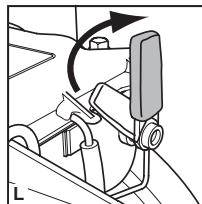
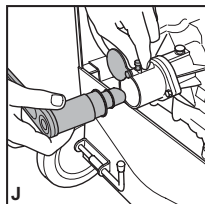
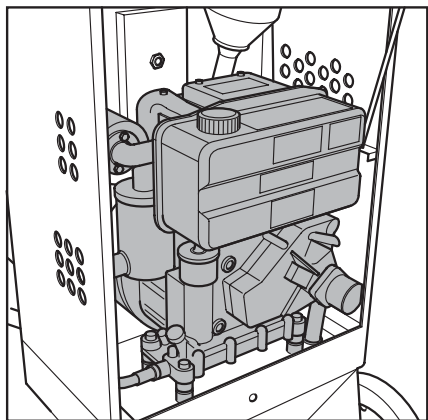

- Caution should be taken when starting unit, always use Anti-Kick Back Starting Handle.
- Ensure handle is correctly engaged in crank barrel (Fig J) before cranking engine.
- Ensure Oil & Fuel levels are checked daily before starting engine.
- Ensure rear door stay is correctly engaged before working in power unit area.
- Keep rear door closed when mixer is running.

4 STOPPING

4.1 Open rear door and move Start / Stop lever to the STOP position (Fig L).

COLD STARTING

4.2 Lift rear door.

4.3 Lift Safety Button up, locate Starting Handle in crank barrel and turn until handle engages (Fig J).

4.4 Engage Start / Stop lever into START position (Fig K).

4.5 Push decompression lever into vertical position and hold (Fig L).

4.6 Crank the engine as fast as possible and move the de-compressor lever into the running position whilst continuing to crank briskly until the engine starts.

4.7 Once the engine starts remove handle and place back in storage, then move Start/Stop lever into the RUN position (Fig M).

WARM STARTING

4.8 Follow the above instructions from 2.2 to 2.6, however start engine with the Start / Stop lever in the RUN position.

EMERGENCY STOP

4.9 Pull handle on top of power unit box (Fig O).



Maintenance Instructions

Before starting any maintenance or repairs, stop engine or switch off motor, and isolate from the main power supply. On completion of maintenance, check that the mixer functions correctly and that all guards are correctly fitted.

ELECTRIC MOTORS

All portable electric appliances are dangerous if abused. This machine will only operate on one voltage. Check the power supply to ensure it corresponds to the voltage as stamped on the motor. Make sure that the motor is switched off before you plug it into the power supply.

220/240v -Always use a Residual Current Device ("RCD"), (earth leakage trip), plugged directly into the 220/240v socket. If using an extension cable, plug it directly into the RCD.

110v -When using a portable transformer it must have a minimum output of 6.3kw and be continuously rated.

- **DO NOT** use an extension cable between the transformer and the power supply.

The symbols on the ON/OFF switch are 0=OFF and I=ON in accordance with international standards.

EXTENSION CABLES

If you need to use an extension cable it must be no longer than 30 metres (100 feet) in length. The wire section for 220/240v must be 2.5mm². The wire section for 110v must be 4mm² on 100XT and 6mm² on other models. Ensure that the extension cable is carefully laid out avoiding liquids, sharp edges and places where vehicles might run over it. Unroll it fully or it will overheat and could catch fire. Make sure that any extension cable connections are dry and safe.

COMBUSTION ENGINES

- **Be aware of exhaust venting directions.**

The engine needs a regular oil check. Try not to run low on fuel as this may result in sediment from the bottom of the tank doing damage to the injector and pump. **Repairs and rectification of pipework and components affected by contaminants in fuel cannot be accepted as warranty, neither will faults caused or contributed to by the machine running out of fuel.** You may need to bleed the fuel system free of air before starting. For initial engine fill or top up use a suitable engine oil of a 10W/30 grade. In your own interests read the makers instruction leaflet issued with the machine before starting up.

DRUM (Removal and Fitment)

This can be instantly removed by unscrewing it counter clockwise in the vertically up position. Lift the drum off the machine using a fork lift, with the forks under the base of the drum. When replacing make sure that the drum shaft is greased before it is fully screwed down on to the shoulder of the shaft, ensure the drum is fully screwed down on to the shoulder or damage will occur. Take care when screwing on the drum, spinning on fast may damage the gearbox.

CLEANING

Wipe off any external material. **DO NOT** use petrol, turpentine, lacquer or paint thinner, dry cleaning fluids or similar products. Never let any liquids near the engine/motor. Use 1" gravel and clean water to clean the inside of the drum.

- **DO NOT** use bricks etc. as this will damage the drum.

DRIVE BELT

- **DO NOT** try to adjust with the engine / motor running.
- **DO NOT** run slack.
- **DO NOT** operate machine with guards removed.

The drive belt is under constant even tension by a spring loaded jockey, this requires no attention. The bearings are sealed for life.

GEARBOX OIL

Note: The original gearbox oil is a synthetic oil and must not be mixed with a mineral oil.

Full gearbox fill 1.0 ltrs, check regularly.

The gearbox was originally filled with: Total :- Transmission W 75W/90 viscosity

Equivalent oils:

Shell :- Tivela SA, Tivela WA, Dentax W

Mobil :- Glygoyle 22

Texaco :- Synlube 90

Castrol :- WM or Alpha SN150

Esso :- GX 75W/90

Caltex :- Synthetic gear lubricant

LUBRICATION AND RUNNING

See Maintenance Schedule Section and Operating Instructions.

Remember that diesel engines vibrate more, so regularly check all nuts and bolts are tight.

To help assist engine running-in, all engines are despatched with an initial 100 litre lubricating oil which must be changed after 100 hours.
All subsequent oil changes must be as specified below.

Lister-Petter 32 & 10 Engines

	Daily	Every 125 Hrs	Every 250 Hrs	Every 500 Hrs	Every 1000 Hrs	Every 2000 Hrs
Check the fuel & lubricating oil levels	✓					
Check for oil & fuel leaks	✓					
Clean, or replace, the air cleaner element under very dusty conditions	✓					
Check the condition of the battery, if fitted		✓				
Clean or replace the air cleaner element under moderately dusty conditions		✓				
Drain the sump and refill with new oil of the correct type and specification as given in engine handbook		✓	✓			
Clean or replace the injectors if the exhaust is dirty			✓			
Renew the fuel filter element if the fuel being used is not perfectly clean			✓			
Replace the air cleaner element				✓		
Examine exhaust & induction systems for leaks, damage or restrictions				✓		
Renew the fuel filter element				✓		
Check the battery charge winding system; refer to Workshop Manual				✓		
Check the valve clearances					✓	
Decarbonise if the engine performance has deteriorated					✓	
Clean the cylinder barrel and heads					✓	
Clean the banjo union at the cylinder head end of oil feed pipe					✓	
Drain, flush and refill the fuel tank						✓

Mixer	Daily	50 Hours	250 Hours	500 Hours	1000 Hours
Grease Yoke Pivot		✓			
Grease Tipping Gear (10 Operations of Grease Gun)			✓		
Remove Drum and Grease Shaft			✓		
Check Nuts and Bolts	✓				
Check Gearbox Oil				✓	✓
Grease Layshaft, Grease Nipple		✓			
Check Components for Leaks	✓				



Checks and Maintenance

Items marked “✓✓” should be serviced by an authorized YANMAR dealer, unless the owner has proficient mechanical ability and the proper tools.

Parts with an asterisk mark “*” are related to the CARB ULG rules.

Yanmar L48 Engine → April '04

	Every month or Every 500 Hrs	Every 3 months or Every 200 Hrs	Every 6 months or Every 400 Hrs	Every year or Every 1000 Hrs
Check the fuel level and re ll. - Before Operation				
Drain the fuel tank	✓			
* Clean the fuel lter		✓		
* Replace the fuel lter			✓	
Check for fuel / oil leakage - After Operation				
* Fuel injection nozzle, Check the injection condition			✓✓	
* Check the fuel injection timing			✓✓	
* Check the fuel injection pump				✓✓
Check the lube oil level in the oil pan and re ll - Before Operation				
Replace the lube oil	1st time	2nd & after		
Clean lube oil lter	1st time		2nd & after	
Check for lube oil leakage - After Operation				
Check the valve clearances				✓
* Check the air cleaner element		✓		
* Replace the air cleaner element			✓	
Check the battery liquid level and re ll - Before Operation				
Check the warning lamps - When Engine Is Started				
Adjusting the intake and exhaust valve clearance			✓✓	

Mixer	Daily	50 Hours	250 Hours	500 Hours	1000 Hours
Grease Yoke Pivot		✓			
Grease Tipping Gear (10 Operations of Grease Gun)			✓		
Remove Drum and Grease Shaft			✓		
Check Nuts and Bolts	✓				
Check Gearbox Oil				✓	✓
Grease Layshaft, Grease Nipple		✓			
Check Components for Leaks	✓				

Technical Data

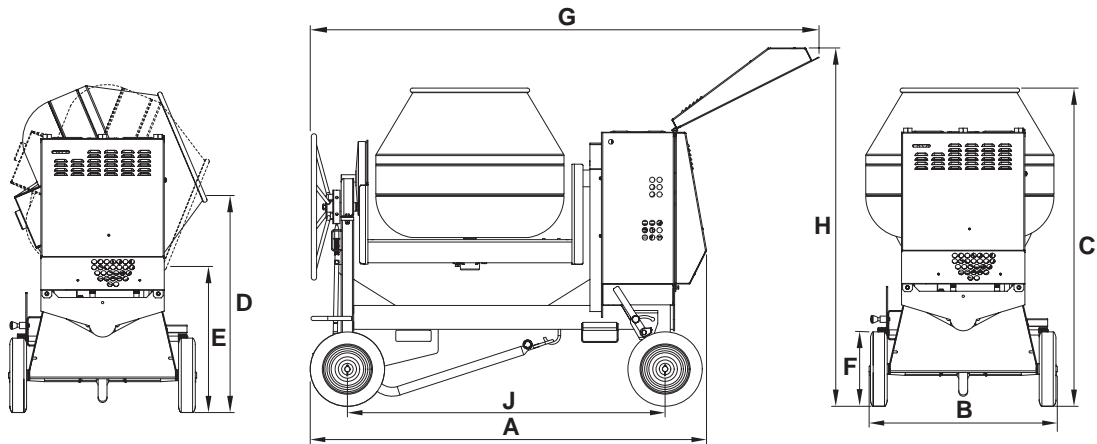

	100XT	150XT	175XT	200XT
A - OVERALL LENGTH (MM)	1665	1665	1890	1890
B - OVERALL WIDTH (MM)	900	900	900	900
C - OVERALL HEIGHT (MM)	1468	1568	1049	1077
D - LOADING HEIGHT (MM)	613	607	713	680
E - DISCHARGE HEIGHT (MM)	350	350	350	350
F - DIAMETER OF WHEELS (MM)	2100	2100	2200	2200
G - OVERALL LENGTH - DOOR OPEN (MM)	1950	1950	1950	1950
H - OVERALL HEIGHT - DOOR OPEN (MM)	1120	1120	1520	1520
J - WHEEL BASE	1120	1120	1520	1520
CUBIC FEET IN/OUT	5/3.5	7/5	8/6	10/7
MIXED BATCH OUTPUT (LTR)	110	160	180	220
MAX DRUM CAPACITY (LTR)	250	300	350	400
MAX DRY MIX DRUM CAPACITY IN (LTR)	160	220	250	310
DRUM SPEED (RPM)	19	19	19	19

ELECTRIC RANGE	100XT	150XT	175XT	200XT	100XT	150XT	175XT	200XT	100XT	150XT	175XT	200XT
	UNLADEN WEIGHT (Kg)	305.5	314.5	322.5	325	303.5	312.5	320.5	323	305.5	314.5	322.5
NOMINAL VOLTAGE (V)	110				240				415			
NOMINAL CURRENT (Amp)	13.7				6.6				3.6			
NOMINAL POWER					1.5							
VOLTAGE FREQUENCY (Hz)					50							
MOTOR RPM	1350				1430				1500			
MOTOR PROTECTION	Thermal / NVR											
POWER CONSUMPTION (Kwh)	1.5											
SOUND POWER LEVEL (LWA)	87dB(A)											
DIESEL RANGE	LISTER				YANMAR							
	100XT	150XT	175XT	200XT	100XT	150XT	175XT	200XT				
UNLADEN WEIGHT (Kg)	367	376	392.5	395	334.5	343.5	350.5	353.5				
ENGINE MODEL	LT1 (Build 32)		LT1 (Build 10)		L48							
NOMINAL POWER (KW)	0.75		1.9		2.3							
STARTING METHOD	Hand Crank				Electric / (Recoil Backup)							
FUEL CAPACITY	5				2.5							
SOUND POWER LEVEL (LWA)	99 dB(A)											

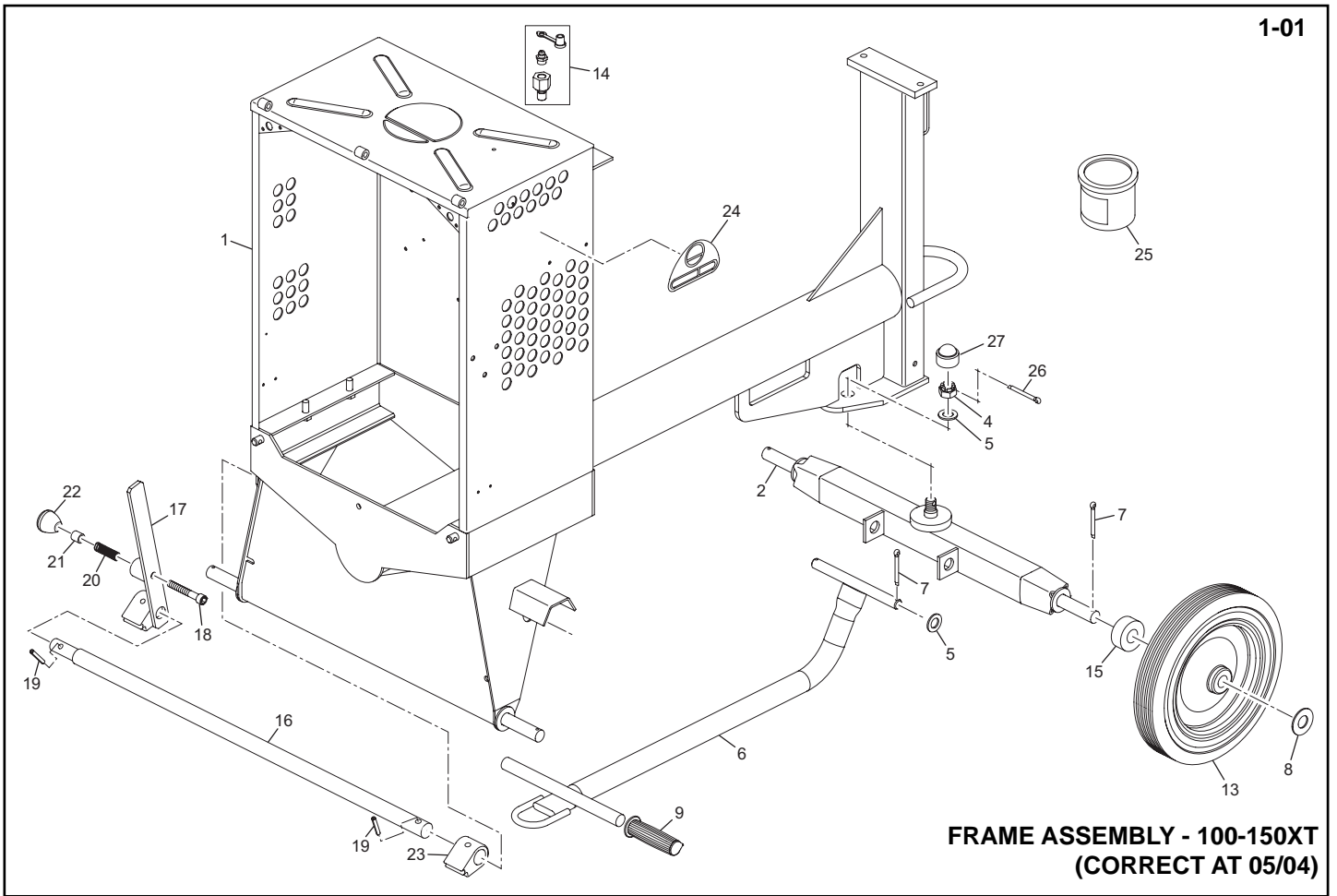

**FRAME ASSEMBLY - 100-150XT
(CORRECT AT 05/04)**

Frame Assembly - 100-150XT

- 1 909-11200..... 1 Frame (100/150XT)
- 2 909-12300..... 1 Axle
- 3
- 4 8-20002..... 1 Nut (M20)
- 5 4-2001..... 3 Washer (M20)
- 6 909-11100 1 Towbar
- 7 3-0006..... 6 Split Pin
- 8 4-0009..... 4 Washer (M26)
- 9 XS35 2 Handle Grip
- 10
- 11
- 12
- 13 60-0284..... 4 Wheel
- 14 909-20000..... 1 Grease Nipple Assembly (→ June'04)
- 15 909-99996..... 4 Spacer
- 16 909-17402..... 1 Brake Bar
- 17 909-99998..... 1 Lever
- 18 7-10015..... 1 Screw (M10x65)
- 19 3-0044..... 2 Spirol Pin
- 20 2-0027..... 1 Spring
- 21 909-99997..... 1 Spacer
- 22 74-0001..... 1 Knob
- 23 909-17401..... 1 Brake Cam
- 24 800-22600..... 1 Decal Kit (100XT)
- 24A 800-22700..... 1 Decal Kit (150XT)
- 24B 800-22800..... 1 Decal Kit (175XT)
- 24C 800-22900..... 1 Decal Kit (200XT)
- 25 1-0519..... A/R Orange Paint (Tin)
- 25A 1-0507..... A/R Orange Paint (Spray)
- 26 3-0049..... 1 Split Pin
- 27 3-4034..... 1 Cap

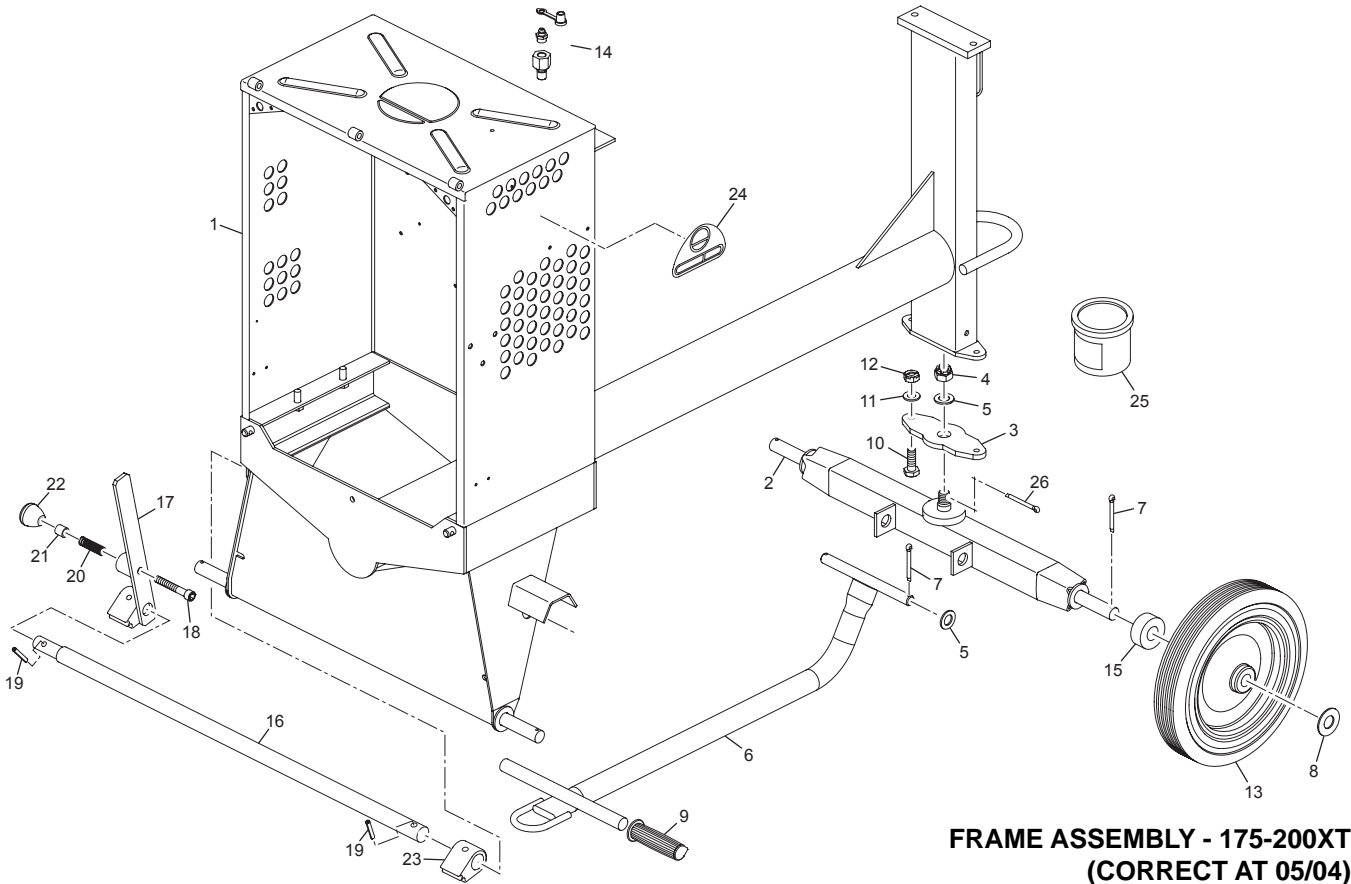

**FRAME ASSEMBLY - 175-200XT
(CORRECT AT 05/04)**

Frame Assembly - 175-200XT

- 1 909-11600 1 Frame (175/200XT)
- 2 909-12300 1 Axle
- 3 909-99935 1 Plate
- 4 8-20002 1 Nut (M20)
- 5 4-2001 3 Washer (M20)
- 6 909-11100 1 Towbar
- 7 3-0006 6 Split Pin
- 8 4-0009 4 Washer (M26)
- 9 XS35 2 Handle Grip
- 10 7-10010 2 Screw (M10x30)
- 11 4-1005 2 Washer (M10)
- 12 8-10001 2 Nut (M10)
- 13 60-0284 4 Wheel
- 14 909-20000 1 Grease Nipple Assembly (→ June'04)
- 15 909-99996 4 Spacer
- 16 909-17402 1 Brake Bar
- 17 909-99998 1 Lever
- 18 7-10015 1 Screw (M10x65)
- 19 3-0044 2 Spirol Pin
- 20 2-0027 1 Spring
- 21 909-99997 1 Spacer
- 22 74-0001 1 Knob
- 23 909-17401 1 Brake Cam
- 24 800-22600 1 Decal Kit (100XT)
- 24A 800-22700 1 Decal Kit (150XT)
- 24B 800-22800 1 Decal Kit (175XT)
- 24C 800-22900 1 Decal Kit (200XT)
- 25 1-0519 A/R Orange Paint (Tin)
- 25A 1-0507 A/R Orange Paint (Spray)
- 26 3-0049 1 Split Pin

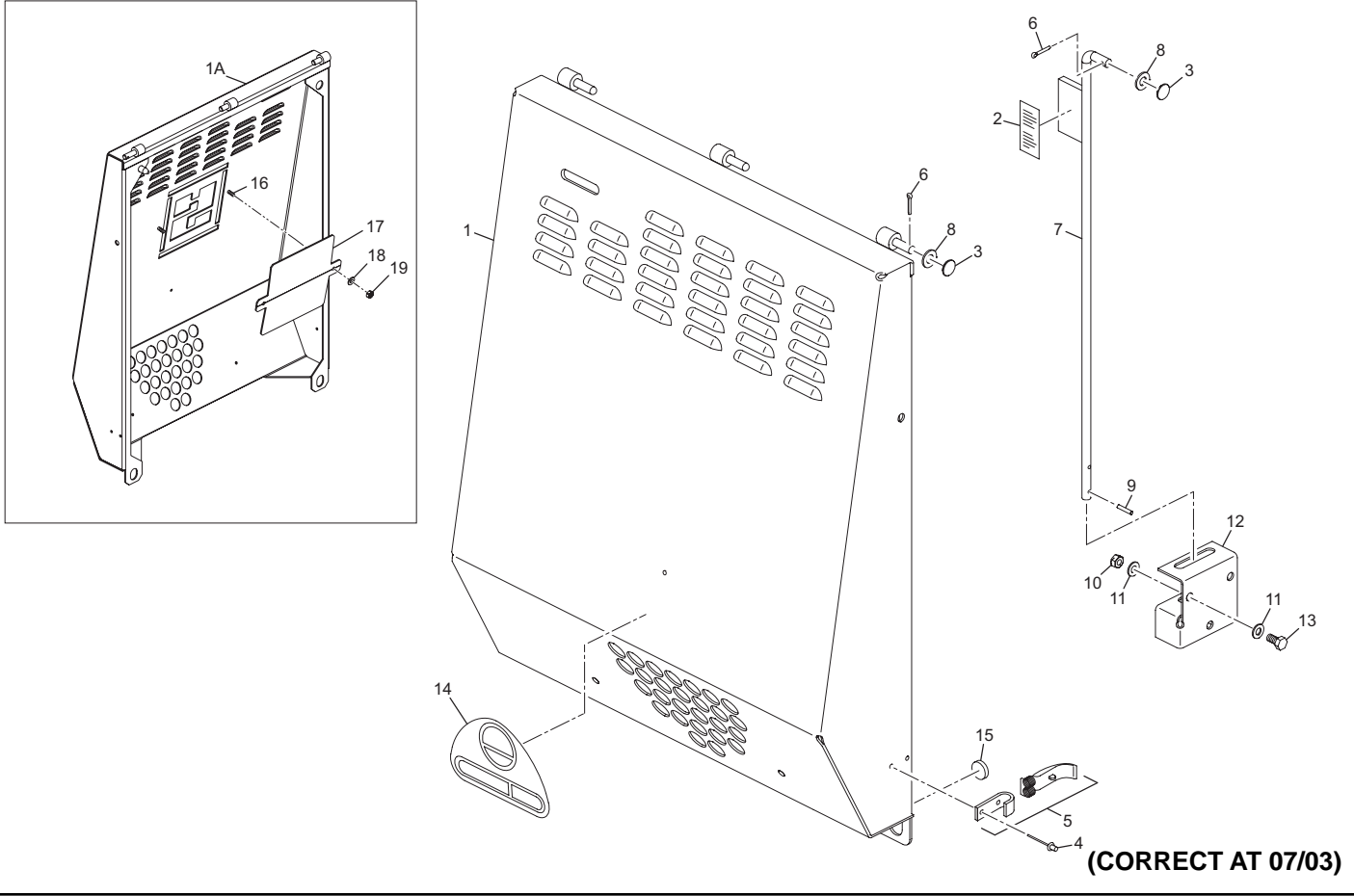

(CORRECT AT 07/03)

Door Assembly

- 1 909-10400..... 1 Cover
- 1A 909-19700..... 1 Hewden Rear Door Assembly
- 2 800-99903..... 1 Decal
- 3 PS071 2 Cap
- 4 3-0008..... 8 Rivet
- 5 908-10700..... 2 Catch
- 6 3-0003..... 2 Split Pin
- 7 909-17600..... 1 Door Stay
- 8 4-10001..... 2 Washer (M10)
- 9 3-0013..... 2 Spirol Pin
- 10 8-8002..... 3 Nut (M8)
- 11 4-8006..... 6 Washer (M8)
- 12 909-99959..... 1 Bracket
- 13 7-8008..... 3 Screw (M8x16)
- 14 1-01 & 1-02 (Item 24)
- 15 3-3000..... 2 Pad
- 16 915-00131..... 2 Stud
- 17 909/99806 1 In I Plate
- 18 4-8006..... 2 Washer (M8)
- 19 8-8002..... 2 Nut (M8)

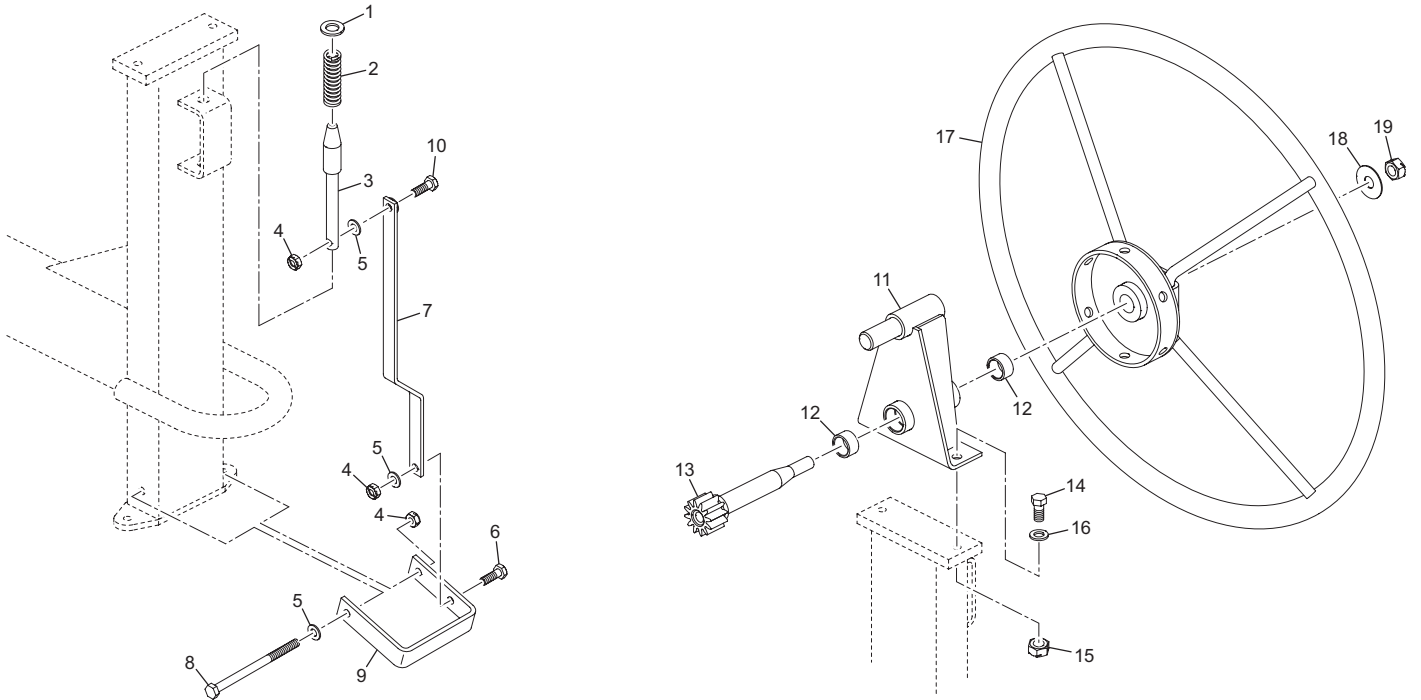

(CORRECT AT 07/03)

Wheel Assembly

1	4-1601.....	1	Washer (M16)
2	2-0029.....	1	Spring
3	909-99910.....	1	Plunger
4	8-10001.....	3	Nut (M10)
5	4-1005.....	7	Washer (M10)
6	7-10010.....	1	Screw (M10x30)
7	909-99926.....	1	Plunger Link
8	9-10015.....	1	Bolt (M10x150)
9	909-99929.....	1	Foot Pedal
10	9-10004.....	1	Bolt (M10x35)
11	909-14800.....	1	Pivot
12	50-000016.....	2	Composite Bush
13	909-14900.....	1	Tip Gear
14	7-12013.....	2	Screw (M12x35)
15	8-12001.....	2	Nut (M12)
16	4-1204.....	4	Washer (M12)
17	909-10500.....	1	Hand Wheel
18	4-1607.....	1	Washer (M16)
19	8-16003.....	1	Nut (M16)

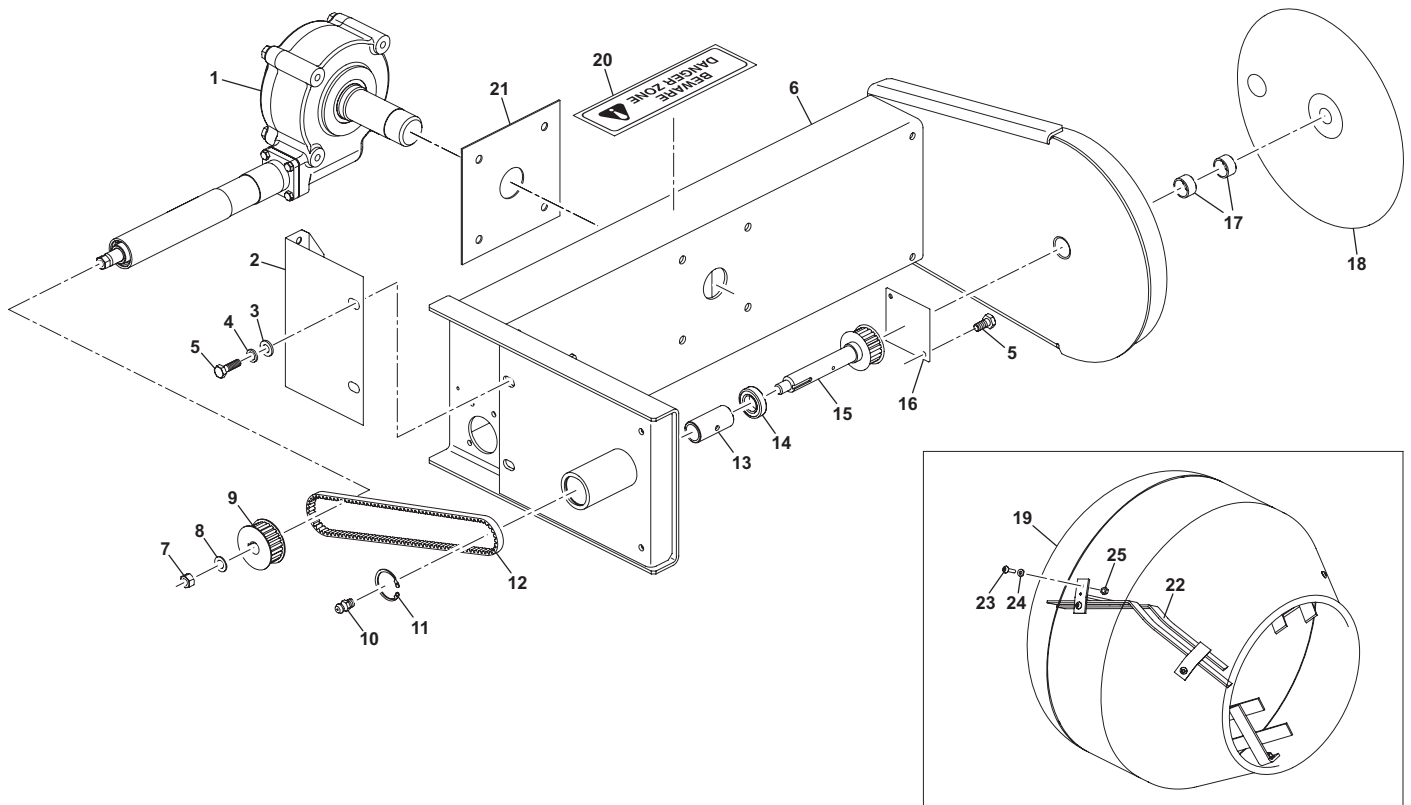

(CORRECT AT 05/04)

Yoke Assembly

4-01

1	☞ 5-01	1	Gearbox	24	4-1201	9	Washer (M12)
2	909-99942	1	Guard	25	8-12001	9	Nut (M12)
3							
4							
5	7-6032	5	Screw (M6x12)				
6	909-10700	1	Yoke (100/150XT)				
6A	909-12200	1	Yoke (175/200XT)				
7	8-12003	1	Nut (M12)				
8	4-1205	1	Washer (M12)				
9	908-15700	1	Pulley (→ May'04)				
9A	909-99807	1	Pulley (↗ May'04)				
10	500-06100	1	Grease Nipple				
11	PS022	1	Circlip				
12	908-15500	1	Drive Belt (→ May'04)				
12A	21-0163	1	Drive Belt (↗ May'04)				
13	909-99932	1	Spacer				
14	PS074	2	Bearing				
15	909-13100	1	Layshaft (→ May'04)				
15A	909-19900	1	Layshaft (↗ May'04)				
16	908-15900	1	Cover				
17	50-000016	2	Bush				
18	908-21200	1	Cover				
19	909-18300	1	Drum (c/w Paddles) (100XT)				
19A	909-18400	1	Drum (c/w Paddles) (150XT)				
19B	909-18500	1	Drum (c/w Paddles) (175XT)				
19C	909-18600	1	Drum (c/w Paddles) (200XT)				
20	800-10441	2	Decal Danger Zone				
21	☞ 5-01	1	Plate				
22	909-19100	1	Paddle Kit (100XT) (↗ July'02)				
22A	909-19200	3	Paddle Kit (150XT) (↗ July'02)				
22B	909-19300	3	Paddle Kit (175XT) (↗ Oct'02)				
22C	909-19400	3	Paddle Kit (200XT) (↗ Aug'02)				
23	7-12017	9	Screw (M12 x 30)				

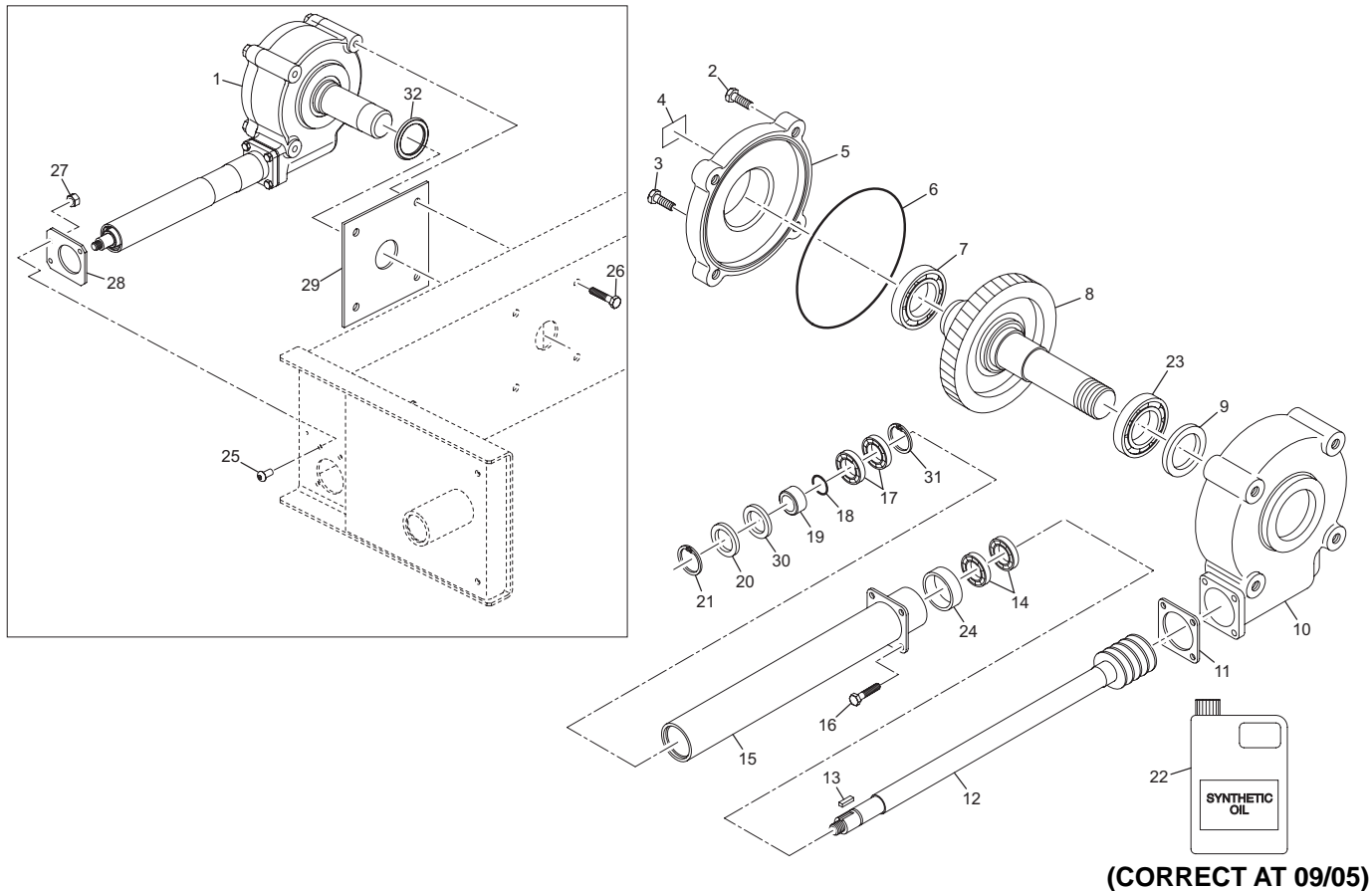

(CORRECT AT 09/05)

Gearbox Assembly

5-01

1	909-161001Gearbox Assy (100/150XT) (→ PM40005925)	29	909-999951Plate
1A	909-130001Gearbox Assy (175/200XT) (→ PM40005925)	30	909-129031Spacer
1B	909-202001Gearbox Assy (100/150XT) (→ PM40005926)	31	3-90031Circlip
1C	909-203001Gearbox Assy (175/200XT) (→ PM40005926)	32	5-00671Seal
2	7-120144Bolt (M12x40)				
3	XS011Bung				
4	908-141001Decal				
5	PS1111Cover				
6	5-00221Seal				
7	PS0021Bearing				
8	909-173001Mainshaft				
9	5-00441Seal				
10	909-130011Case				
11	5-00431Gasket				
12	909-150001Wormshaft (100/150XT)				
12A	909-128001Wormshaft (175/200XT)				
13	908-999011Key				
14	53-00102Bearing				
15	909-151001Tube Carrier (100-150XT)				
15A	909-129001Tube Carrier (175-200XT)				
16	7-80124Bolt (M8x25)				
17	PS0132Bearing				
18	5-00151Seal				
19	909-129041Spacer				
20	PS0161Seal				
21	MS221Circlip				
22	1-0120A/ROil				
23	53-00041Bearing				
24	909-129021Spacer				
25	7-80493Screw (M8x16)				
26	7-120044Bolt (M12x25)				
27	8-80023Nut (M8)				
28	908-160001Plate				

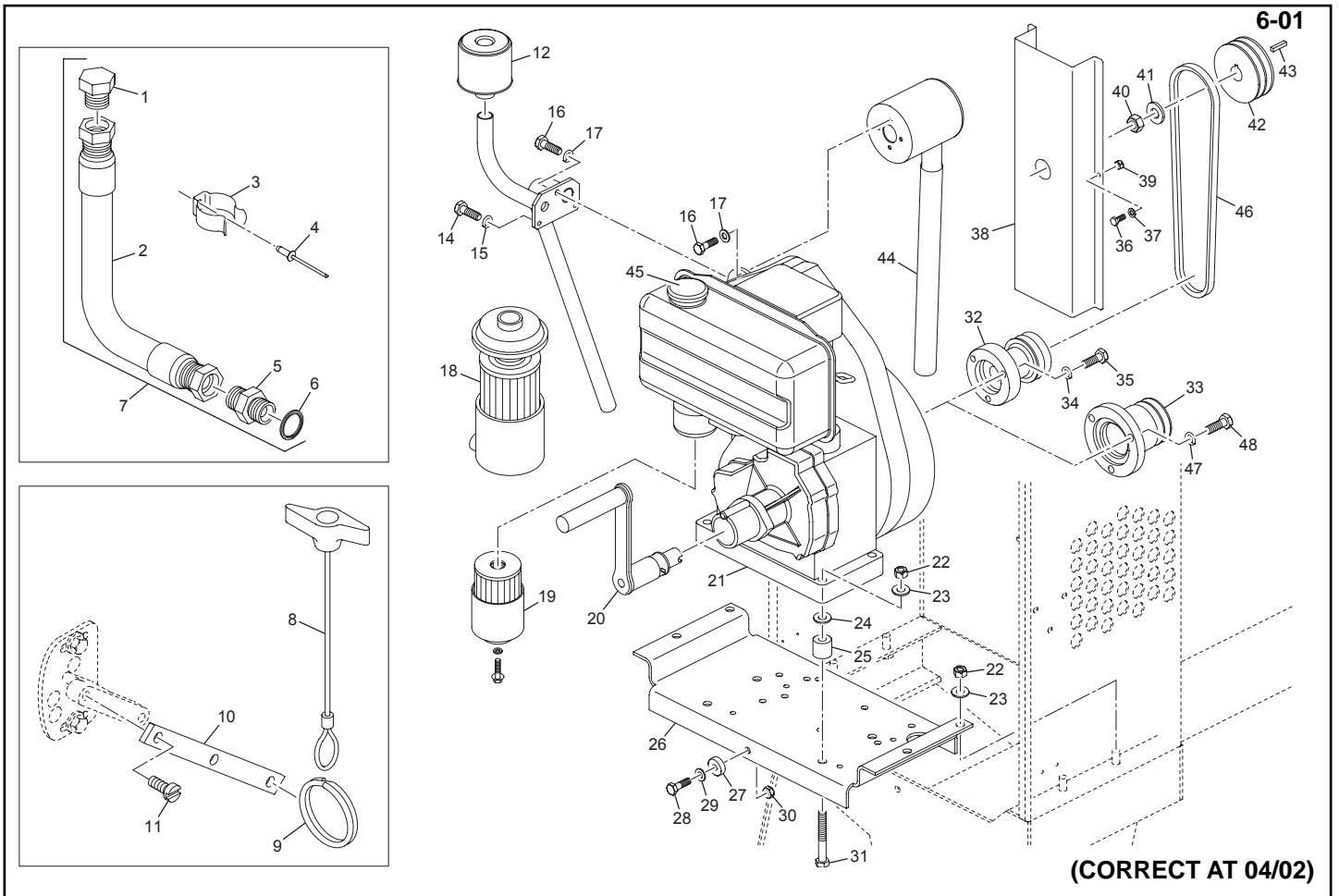

Engine Assembly (Lister → July'02)

6-01

1	6-0003.....1	Blank	31	9-12018.....4	Bolt (M12x100) (→ July'02)
2	32-0116.....1	Hose	32	PS040.....1	Pulley (Build 10)
3	3-1010.....1	Clip	33	PS097.....1	Pulley (Build 32)
4	3-0043.....1	Rivet	34	4-1003.....3	Washer (M10)
5	6-0020.....1	Adaptor	35	9-10009.....3	Bolt (M10x45)
6	5-0020.....1	Seal	36	9-6001.....2	Screw (M6x16)
7	39-1220.....1	Hose Kit	37	4-6001.....4	Washer (M6)
8	21-0107.....1	Stop Cable	38	909-99941.....1	Guard (→ July'02)
9	2-0010.....1	Ring	39	8-6002.....2	Nut (M6)
10	908-21800.....1	Lever	40	8-16002.....1	Nut (M16)
11	7-4002.....2	Screw (M4)	41	4-1602.....1	Washer (M16)
12	PS087.....1	Air Filter (Build 32)	42	909-99964.....1	Pulley
13	909-14100.....1	Exhaust (Build 32)	43	909-99968.....1	Key
14	9-6001.....2	Bolt (M6x16)	44	909-14400.....1	Exhaust (Build 10)
15	4-6005.....2	Washer (M6)	45	908-18700.....1	Cap
16	7-8008.....3	Bolt (M8)	46	21-0109.....2	Belt (A37)
17	4-8003.....3	Washer (M8)	47	4-1202.....3	Washer (M12)
18	908-14200.....1	Air Filter (Build 10)	48	9-12006.....3	Bolt (M12x35)
19	908-18600.....1	Fuel Filter	-	800-21510.....A/R	Decal Lister Maintenance
20	908-22500.....1	Handle	-	800-21531.....A/R	Decal Lister Starting
21	908-20800.....1	Engine (Build 32)	-	800-99916.....A/R	Decal Lister Noise
21A	908-20900.....1	Engine (Build 10)			
22	8-12001.....8	Nut			
23	4-1205.....12	Washer (M12)			
24	4-1201.....24	Washer (M12) (→ July'02)			
25	909-99975.....4	Spacer (→ July'02)			
26	909-99986.....1	Engine Deck (→ July'02)			
27	909-99980.....1	Spacer (→ July'02)			
28	9-10004.....1	Bolt (M10x35) (→ July'02)			
29	4-1005.....2	Washer (M10)			
30	8-10001.....1	Nut (M10)			

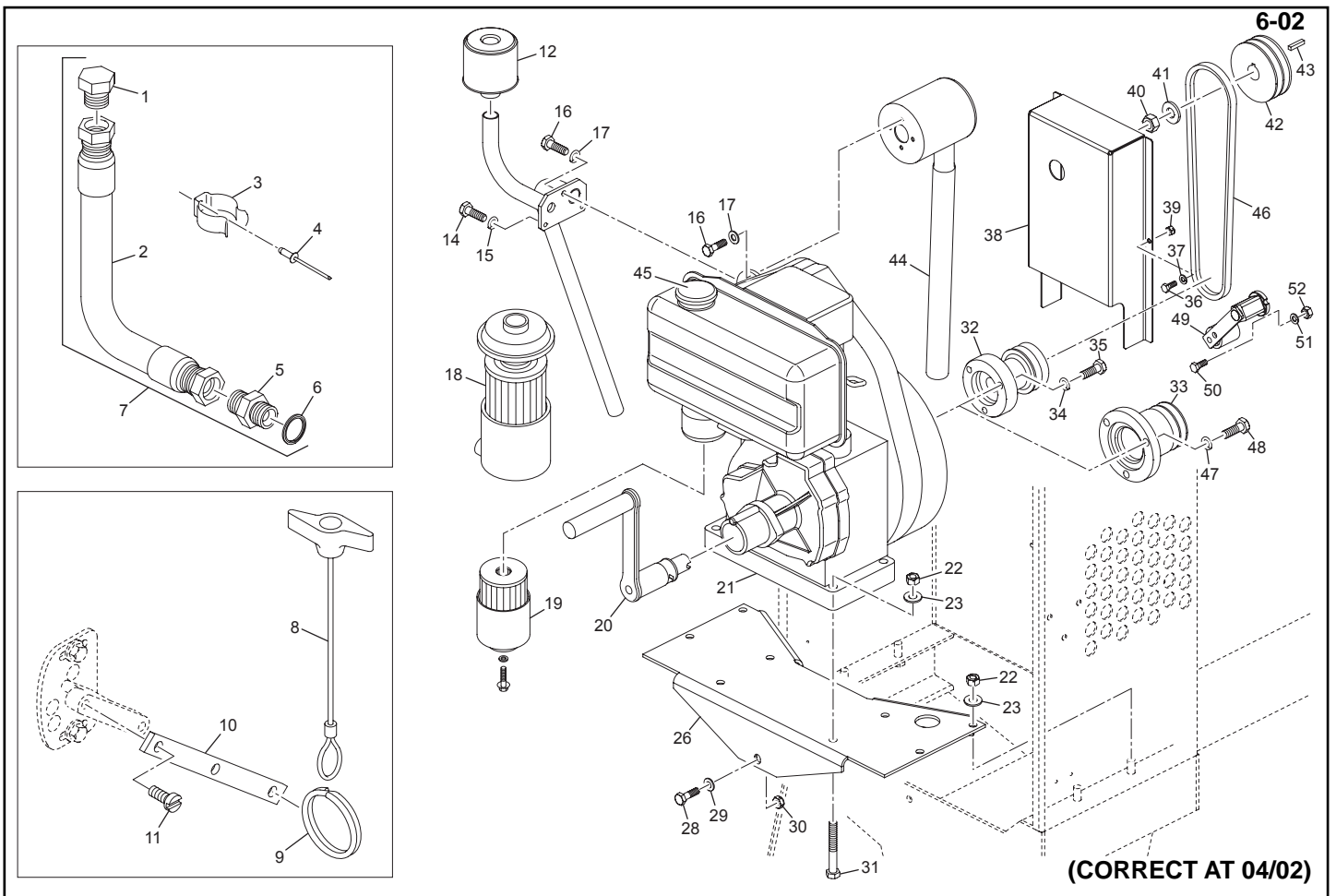

Engine Assembly (Lister → July'02)

6-02

1	6-0003.....	1	Blank	31	9-12019.....	4	Bolt (M12x55) (→ July'02)
2	32-0116	1	Hose	32	PS040	1	Pulley (Build 10)
3	3-0008.....	1	Clip	33	PS097	1	Pulley (Build 32)
4	3-0043.....	1	Rivet	34	4-1003.....	3	Washer (M10)
5	6-0020.....	1	Adaptor	35	9-10009.....	3	Bolt (M10x45)
6	5-0020.....	1	Seal	36	9-6001.....	2	Screw (M6x16)
7	39-1220.....	1	Hose Kit	37	4-6001.....	4	Washer (M6)
8	21-0107.....	1	Stop Cable	38	909-99802.....	1	Guard (Build 10) (→ July'02)
9	2-0010.....	1	Ring		909-99903.....	1	Guard (Build 32) (→ July'02)
10	908-21800.....	1	Lever	39	8-6002.....	2	Nut (M6)
11	7-4002.....	2	Screw (M4)	40	8-16002.....	1	Nut (M16)
12	PS087	1	Air Filter (Build 32)	41	4-1602.....	1	Washer (M16)
13	909-14100.....	1	Exhaust (Build 32)	42	909-99964.....	1	Pulley
14	9-6001.....	2	Bolt (M6x16)	43	909-99968.....	1	Key
15	4-6005.....	2	Washer (M6)	44	909-14400.....	1	Exhaust (Build 10)
16	7-8008.....	3	Bolt (M8)	45	908-18700.....	1	Cap
17	4-8003.....	3	Washer (M8)	46	21-0109.....	2	Belt (A37)
18	908-14200.....	1	Air Filter (Build 10)	47	4-1202.....	3	Washer (M12)
19	908-18600.....	1	Fuel Filter	48	9-12006.....	3	Bolt (M12x35)
20	908-22500.....	1	Handle	49	909-99999.....	1	Jockey Belt Tensioner (→ July'02)
21	908-20800.....	1	Engine (Build 32)	50	7-5020.....	1	Screw (M5x10) (→ July'02)
21A	908-20900.....	1	Engine (Build 10)	51	4-5002.....	1	Washer (M5) (→ July'02)
22	8-12001.....	8	Nut	52	5-5002.....	1	Nut (M5) (→ July'02)
23	4-1205.....	12	Washer (M12)	-	800-21510.....	A/R	Decal Lister Maintenance
24				-	800-21531.....	A/R	Decal Lister Starting
25				-	800-99916.....	A/R	Decal Lister Noise
26	909-99991.....	1	Engine Deck (→ July'02)				
27							
28	9-10005.....	1	Bolt (M10x25) (→ July'02)				
29	4-1005.....	2	Washer (M10)				
30	8-10001.....	1	Nut (M10)				

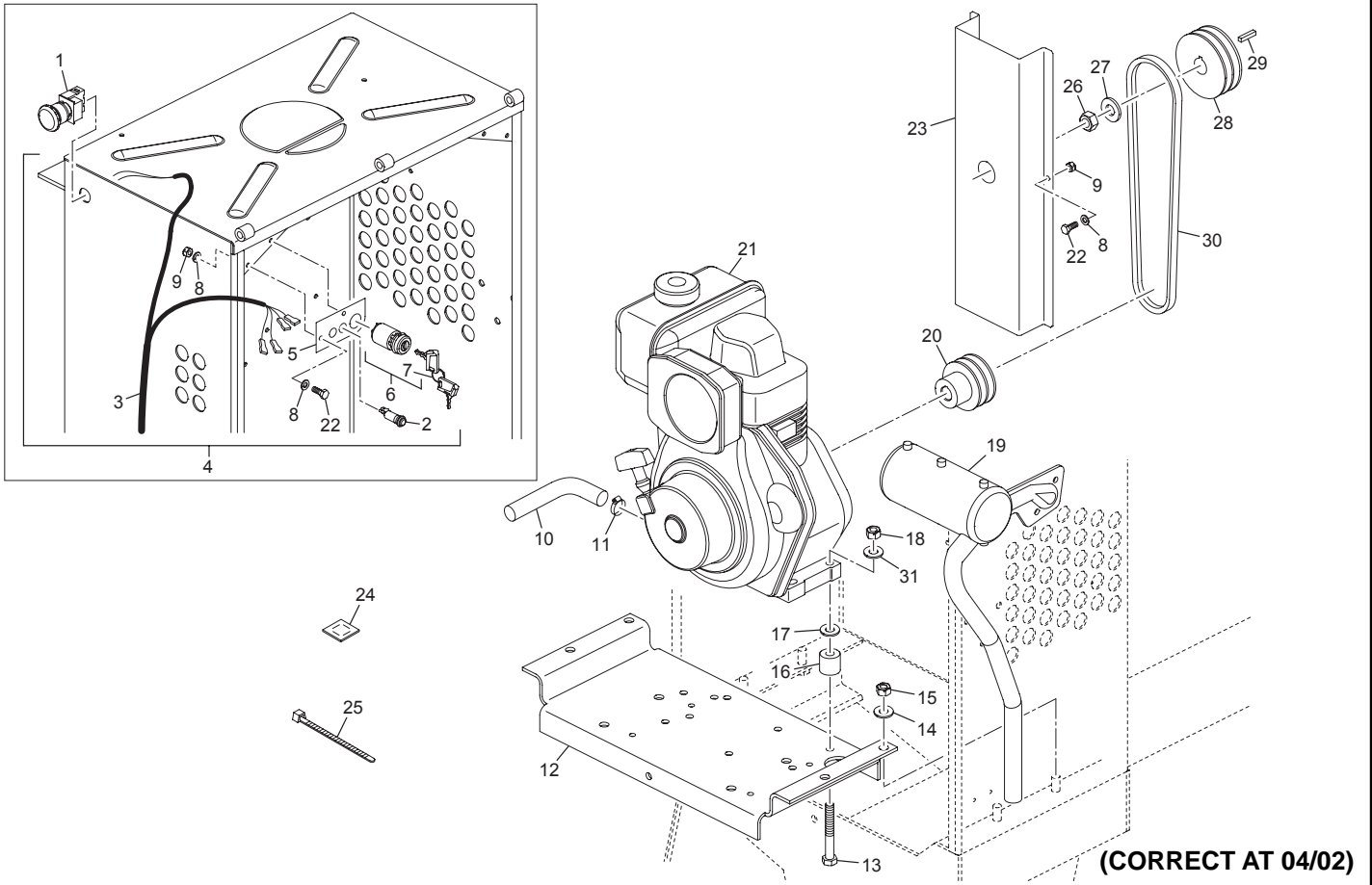
Engine Assembly (Yanmar → Oct'01)

7-01

1	70-0049	1	Emergency Stop Button (→ Oct'01)	31	4-1005	4	Washer (M10)
2	70-0012	1	Indicator Red	-	800-10420	A/R	Decal Hot Parts
3	71-0167	1	Harness (Stop/Start) (→ Oct'01)	-	800-21512	A/R	Decal Yanmar Maintenance
4	71-0157	1	Harness Assy (Complete) (→ Oct'01)	-	800-21520	A/R	Decal Charge Light
5	909-99972	1	Ignition Switch Plate	-	800-21530	A/R	Decal Yanmar Starting (→ Oct'01)
6	70-0184	1	Ignition Switch (C/W Keys)	-	800-99916	A/R	Decal Yanmar Noise
7	70-0185	1	Ignition Keys	-	800-99916	1	Decal Motor Noise
8	4-6001	8	Washer (M6)				
9	8-6002	4	Nut (M6)				
10	31-0105	1	Drain Hose				
11	200-08400	1	Jubilee Clip				
12	909-99986	1	Engine Deck				
13	9-10011	4	Bolt (M10x50)				
14	4-1204	4	Washer (M12)				
15	8-12001	4	Nut (M12)				
16	909-99976	4	Spacer				
17	4-1001	24	Washer (M10)				
18	8-10001	4	Nut (M10)				
19	909-14300	1	Exhaust				
20	909-99970	1	Pulley				
21	20-0023	1	Engine Yanmar L40 ARE-BE (→ Oct'01)				
22	9-6001	4	Screw (M6x16)				
23	909-99941	1	Guard				
24	900-99903	A/R	Pad				
25	1-0005	A/R	Cable Tie				
26	8-16002	1	Nut (M16)				
27	4-1602	1	Washer (M16)				
28	909-99964	1	Pulley				
29	909-99968	1	Key				
30	21-0110	2	Belt (A36)				

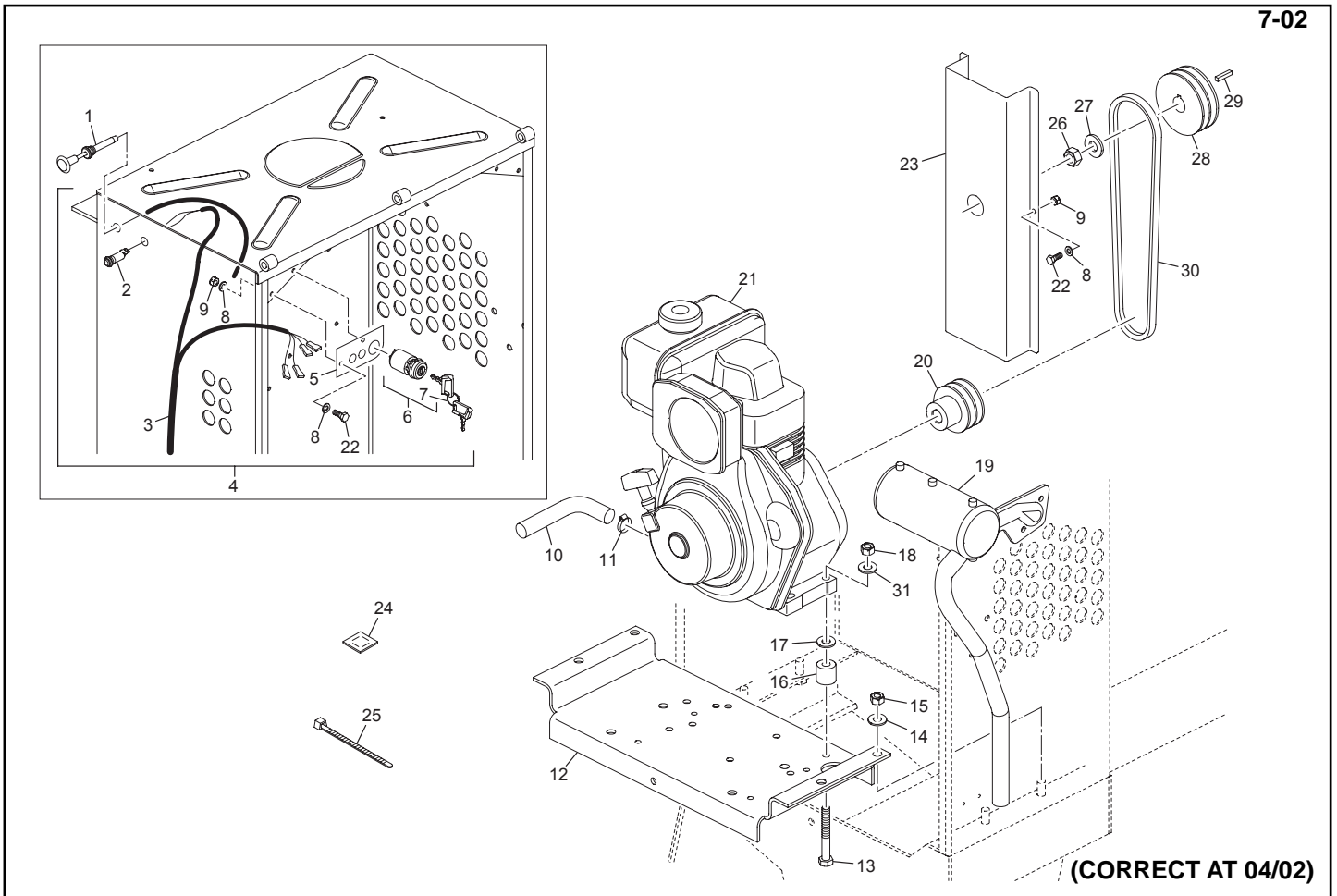

Engine Assembly (Yanmar → Oct'01 → July'02)

7-02

1	21-0114	1	Emergency Stop & Cable Assy (→ Oct'01)	31	4-1005	4	Washer (M10)
2	70-0012	1	Indicator Red	-	800-10420	A/R	Decal Hot Parts
3	71-0174	1	Harness (Stop/Start) (→ Oct'01)	-	800-21512	A/R	Decal Yanmar Maintenance
4	71-0173	1	Harness Assy (Complete) (→ Oct'01)	-	800-21520	A/R	Decal Charge Light
5	909-99972	1	Ignition Switch Plate	-	800-21534	A/R	Decal Yanmar Starting (→ Oct'01)
6	70-0184	1	Ignition Switch (C/W Keys)	-	800-99916	A/R	Decal Yanmar Noise
7	70-0185	1	Ignition Keys				
8	4-6001	8	Washer (M6) (→ July'02)				
9	8-6002	4	Nut (M6) (→ July'02)				
10	31-0105	1	Drain Hose				
11	200-08400	1	Jubilee Clip				
12	909-99986	1	Engine Deck (→ July'02)				
13	9-10011	4	Bolt (M10x50) (→ July'02)				
14	4-1204	4	Washer (M12)				
15	8-12001	4	Nut (M12)				
16	909-99976	4	Spacer (→ July'02)				
17	4-1001	24	Washer (M10) (→ July'02)				
18	8-10001	4	Nut (M10)				
19	909-14300	1	Exhaust				
20	909-99970	1	Pulley				
21	20-0024	1	Engine Yanmar				
			L40 ARE-BE-BE2 (→ Oct'01)				
22	9-6001	4	Screw (M6x16) (→ July'02)				
23	909-99941	1	Guard (→ July'02)				
24	900-99903	A/R	Pad				
25	1-0005	A/R	Cable Tie				
26	8-16002	1	Nut (M16)				
27	4-1602	1	Washer (M16)				
28	909-99964	1	Pulley				
29	909-99968	1	Key				
30	21-0110	2	Belt (A36) (→ July'02)				

Engine Assembly (Yanmar ↳ July'02)

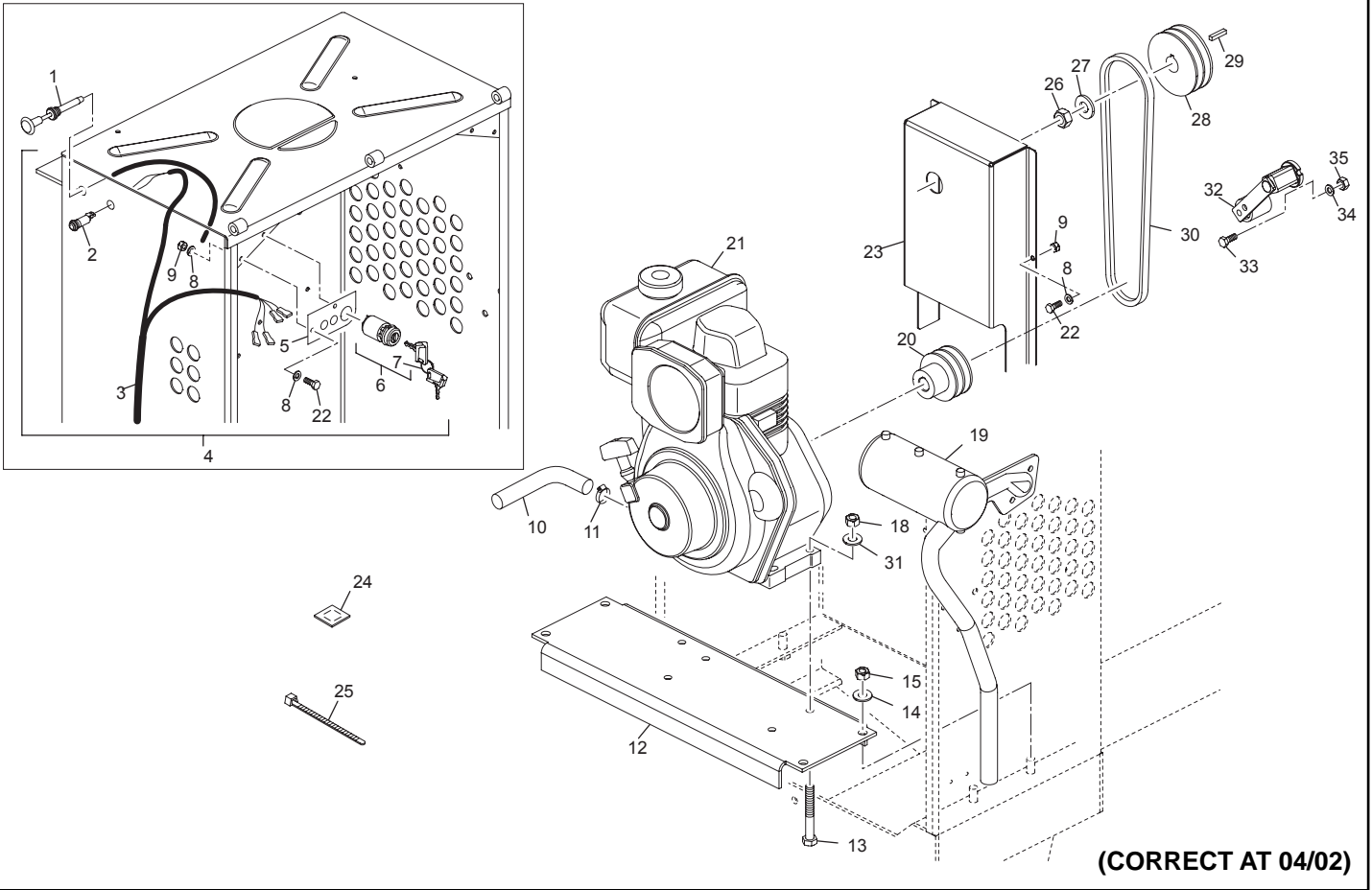
7-03



Engine Assembly (Yanmar ↳ July'02)

7-03

1	21-0114	1	Emergency Stop & Cable Assy	31	4-1005	4	Washer (M10)
2	70-0012	1	Indicator Red	32	909-99999	1	Jockey (Belt Tensioner) (↳ July'02)
3	71-0174	1	Harness (Stop/Start)	33	7-5020	1	Screw (M5x10) (↳ July'02)
4	71-0173	1	Harness Assy (Complete)	34	8-5002	1	Nut (M5) (↳ July'02)
5	909-99972	1	Ignition Switch Plate	35	4-5002	1	Washer (M5) (↳ July'02)
6	70-0184	1	Ignition Switch (C/W Keys)	-	800-10420	A/R	Decal Hot Parts
7	70-0185	1	Ignition Keys	-	800-21512	A/R	Decal Yanmar Maintenance
8	4-6001	10	Washer (M6) (↳ July'02)	-	800-21520	A/R	Decal Charge Light
9	8-6002	5	Nut (M6) (↳ July'02)	-	800-21534	A/R	Decal Yanmar Starting
10	31-0105	1	Drain Hose	-	800-99916	A/R	Decal Yanmar Noise
11	200-08400	1	Jubilee Clip				
12	909-99992	1	Engine Deck (↳ July'02)				
13	9-10005	4	Bolt (M10x45) (↳ July'02)				
14	4-1204	4	Washer (M12)				
15	8-12001	4	Nut (M12)				
16							
17							
18	8-10001	4	Nut (M10)				
19	909-14300	1	Exhaust				
20	909-99970	1	Pulley				
21	20-0024	1	Engine Yanmar L40 ARE-BE-BE2				
22	9-6001	5	Screw (M6x16) (↳ July'02)				
23	909-99801	1	Guard (↳ July'02)				
24	900-99903	A/R	Pad				
25	1-0005	A/R	Cable Tie				
26	8-16002	1	Nut (M16)				
27	4-1602	1	Washer (M16)				
28	909-99964	1	Pulley				
29	909-99968	1	Key				
30	21-0117	2	Belt (A35.5) (↳ July'02)				

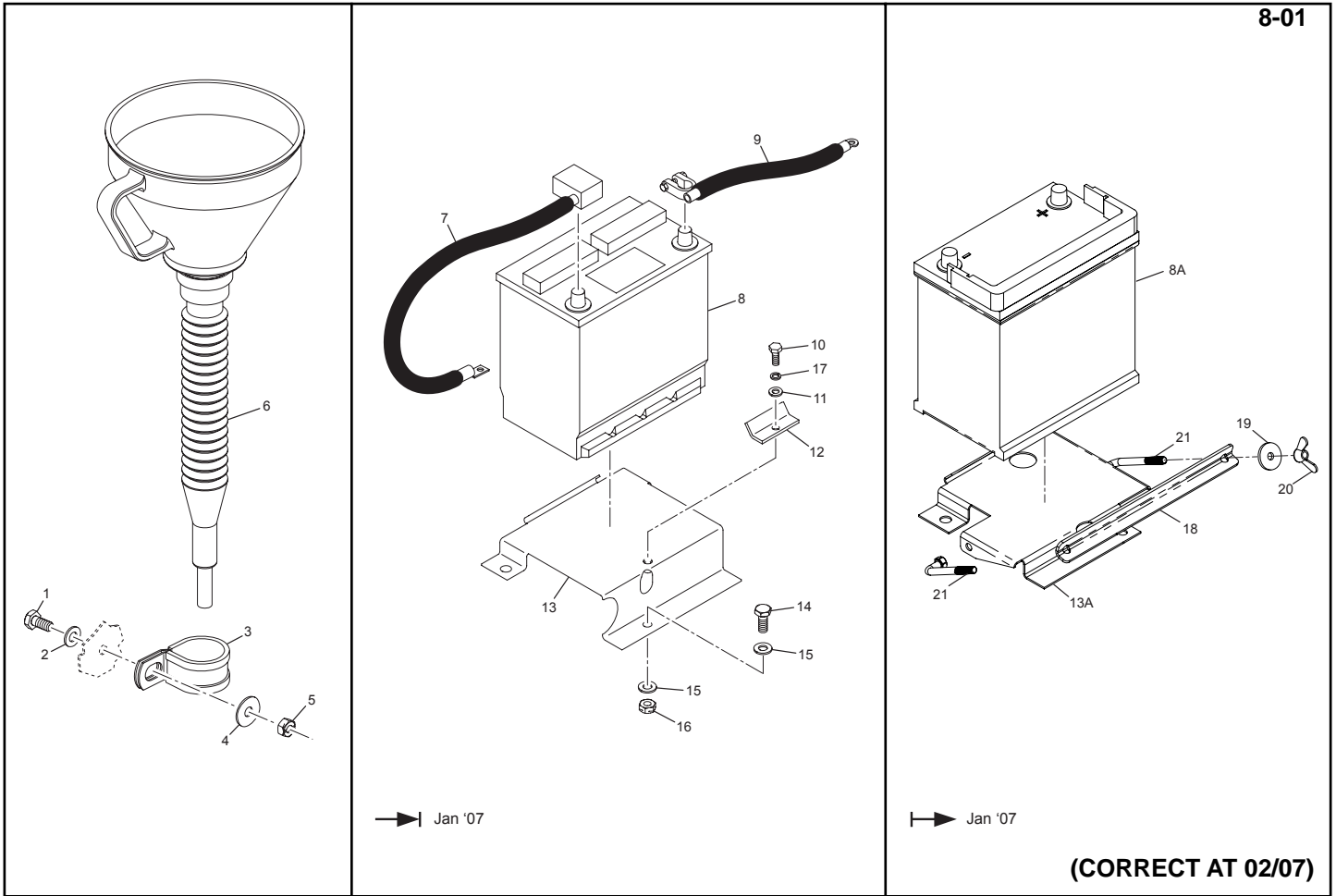

Funnel Assembly / Battery Assembly

1	7-8008.....	1	Bolt (M8x16)
2	4-8006.....	1	Washer (M8)
3	200-06560.....	1	P-Clip
4	4-8008.....	1	Washer (5/16")
5	8-8002.....	1	Nut (M8)
6	92-99901.....	1	Funnel
7	140-05500.....	1	Cable (Positive)
8	909-99818.....	1	Kit Battery (→ Jan '07)
8A	100-05300.....	1	Battery (→ Jan '07)
9	140-05100.....	1	Cable (Earth)
10	7-8011.....	1	(M8x20)
11	4-8006.....	1	Washer (M8)
12	909-99949.....	1	Clamp
13	909-15800.....	1	Battery Deck (→ July '02)
13	909-99817.....	1	Kit Battery Deck (→ Jan '07)
13A	909-99816.....	1	Battery Deck (→ Jan '07)
14	7-10005.....	1	Bolt (M10x25)
15	4-1005.....	2	Washer (M10)
16	8-10001.....	1	Nut (M10)
17	4-8003.....	1	Washer Spring (M8)
18	909-99814.....	1	Clamp Battery
19	05.3.062.....	2	Washer (Dia 30 x 3.3)
20	8-8012.....	2	Wing Nut (M8)
21	909-99815.....	2	Pivot Clamp

Motor Assembly (→ July'02)

9-01

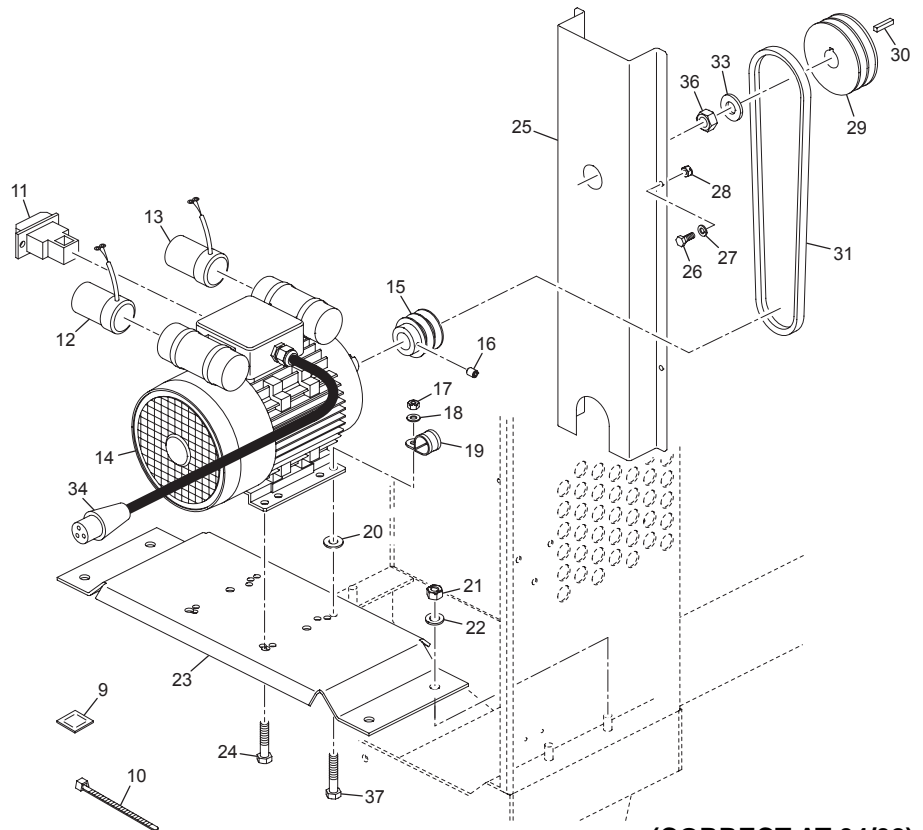
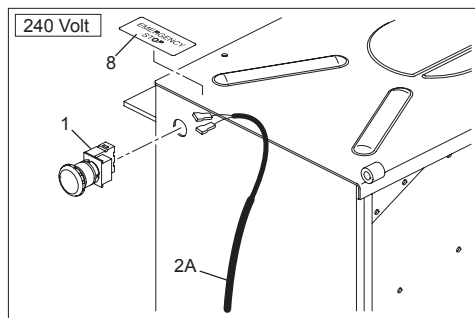
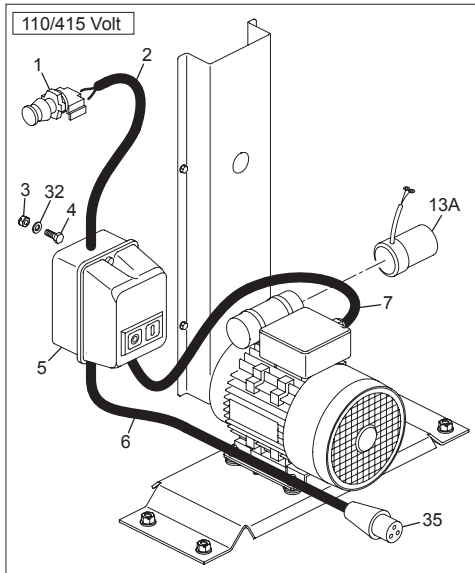

(CORRECT AT 04/02)

Motor Assembly (→ July'02)

9-01

1	70-0049	1	Switch Emergency Stop	28	8-6002	4	Nut (M6) (→ July'02)
2	71-0159	1	Harness Emergency Stop (110V / 415V)	29	909-99964	1	Pulley
2A	71-0172	1	Harness Emergency Stop (240V)	30	909-99968	1	Key
3	8-4004	2	Nut (M4)	31	20-0110	2	Belt (A37) (→ July'02)
4	9-4001	2	Bolt (M4x12)	32	4-4001	2	Washer
5	908-22000	1	Switchbox (110V)	33	4-1602	1	Washer (M16)
5A	908-20000	1	Switchbox (415V)	34	918-28500	1	Plug (240V 16 amp)
6	71-0160	1	Harness Power (c/w 110V 32Amp Plug)	35	918-30100	1	Plug (110V 32 amp)
6A	71-0165	1	Harness Power (c/w 415V 32Amp Plug)	35A	70-0189	1	Plug (415V 32 amp)
7	71-0161	1	Harness Motor (110V)	36	8-16002	1	Nut (M16)
7A	71-0166	1	Harness Motor (415V)	37	9-8003	1	Bolt (M8x35) (→ July'02)
8	900-11600	1	Decal Emergency Stop	38	909-20400	1	Replacment Motor Kit (110V)
9	900-99903	A/R	Pad	38A	909-20600	1	Replacment Motor Kit (240V)
10	1-0005	A/R	Cable Tie	-	800-21513	1	Decal Motor Maintenance
11	70-0044	1	Switch	-	800-21533	1	Decal Motor Start Up
12	70-0042	1	Run Capacitor (240V)				
13	70-0043	1	Start Capacitor (240V)				
13A	70-0187	1	Start Capacitor (110V)				
14	38	1	Motor (110V)				
14A	38A	1	Motor (240V)				
14B	908-19900	1	Motor (415V)				
15	908-14800	1	Pulley				
16	7-8006	1	Screw (M8x10)				
17	8-8002	4	Nut (M8)				
18	4-8006	4	Washer (M8)				
19	900-10200	1	P-Clip				
20	4-8008	24	Washer (M8) (→ July'02)				
21	8-12001	4	Nut (M12)				
22	4-12004	4	Washer (M12)				
23	909-99937	1	Motor Deck				
24	9-8008	3	Bolt (M8x30) (→ July'02)				
25	909-99940	1	Guard				
26	9-6001	4	Screw (M6x16) (→ July'02)				
27	4-6001	8	Washer (M6) (→ July'02)				

Motor Assembly (→ July'02, → Mar'06)

9-02

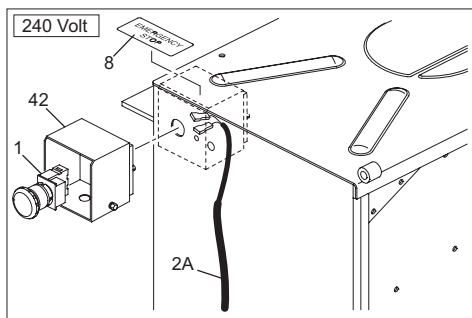
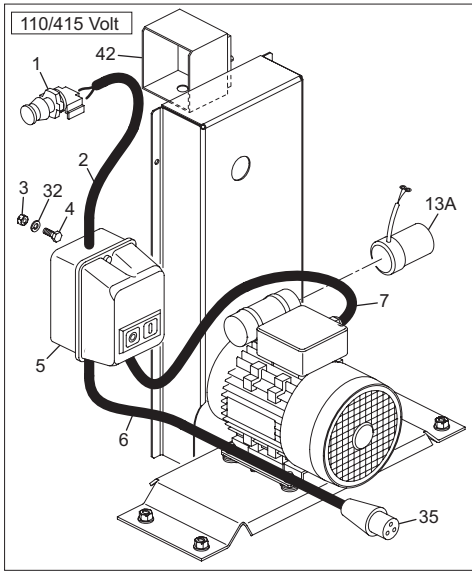

Item 42, should only be fitted by a qualified electrician.

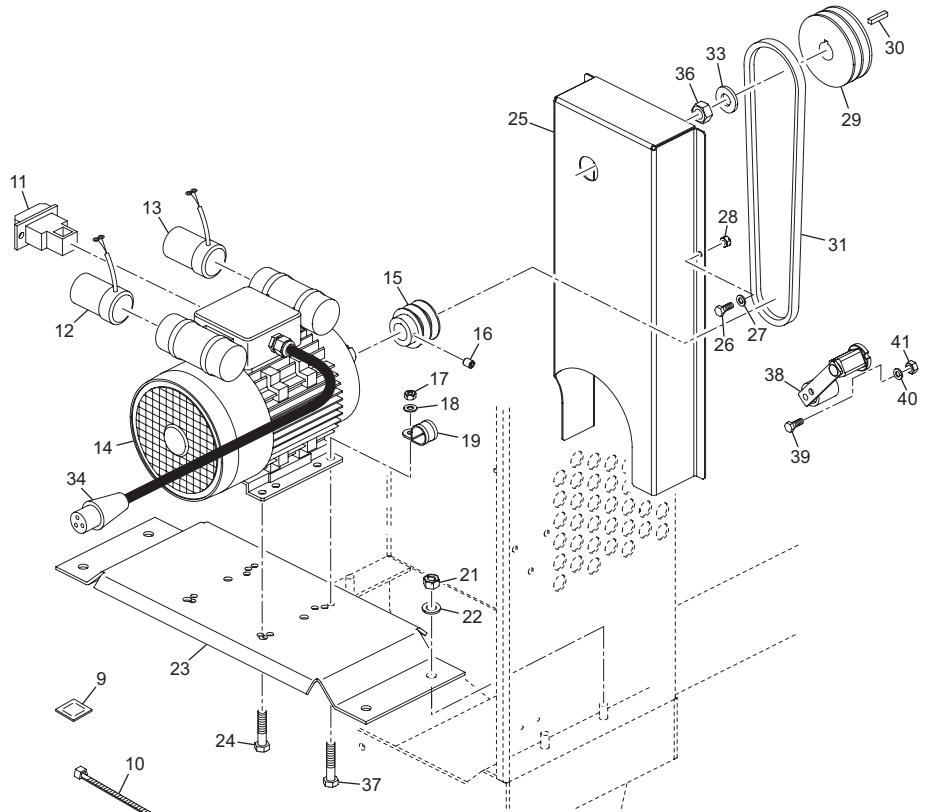

(CORRECT AT 02/06)

Motor Assembly (→ July'02, → Mar'06)

9-02

1	70-0049	1	Switch Emergency Stop	28	8-6002	4	Nut (M6)
2	71-0159	1	Harness Emergency Stop (110V / 415V)	29	909-99964	1	Pulley
2A	71-0172	1	Harness Emergency Stop (240V)	30	909-99968	1	Key
3	8-4004	2	Nut (M4)	31	21-0111	2	Belt (A38) (→ July'02)
4	9-4001	2	Bolt (M4x12)	32	4-4001	2	Washer
5	908-22000	1	Switchbox (110V)	33	4-1602	1	Washer (M16)
5A	908-20000	1	Switchbox (415V)	34	918-28500	1	Plug (240V 16 amp)
6	71-0160	1	Harness Power (c/w 110V 32Amp Plug)	35	918-30100	1	Plug (110V 32 amp)
6A	71-0165	1	Harness Power (c/w 415V 32Amp Plug)	35A	70-0189	1	Plug (415V 32 amp)
7	71-0161	1	Harness Motor (110V)	36	8-16002	1	Nut (M16)
7A	71-0166	1	Harness Motor (415V)	37	24	4	Bolt (M10x25) (→ July'02)
8	900-11600	1	Decal Emergency Stop	38	909-99999	1	Jockey (Belt Tensioner) (→ July'02)
9	900-99903	A/R	Pad	39	7-5020	1	Screw (M5x10) (→ July'02)
10	1-0005	A/R	Cable Tie	40	8-5002	1	Nut (M5) (→ July'02)
11	70-0044	1	Switch	41	4-5002	1	Washer (M5) (→ July'02)
12	70-0042	1	Run Capacitor (240V)	42	909-20100	1	Emergency Stop Cover Kit (→ March'04)
13	70-0043	1	Start Capacitor (240V)	43	909-20400	1	Replacement Motor Kit (110V)
13A	70-0187	1	Start Capacitor (110V)	43A	909-20600	1	Replacement Motor Kit (240V)
14	43	1	Motor (110V)	-	800-21513	1	Decal Motor Maintenance
14A	43A	1	Motor (240V)	-	800-21533	1	Decal Motor Start Up
14B	908-19900	1	Motor (415V)	-	800-99916	1	Decal Motor Noise
15	908-14800	1	Pulley				
16	7-8006	1	Screw (M8x10)				
17	8-10001	4	Nut (M10) (July'02)				
18	4-1005	8	Washer (M10) (July'02)				
19	900-10200	1	P-Clip				
20	4-8008	24	Washer (M8)				
21	8-12001	4	Nut (M12)				
22	4-12004	4	Washer (M12)				
23	909-99937	1	Motor Deck				
24	7-10005	4	Bolt (M10x25) (→ July'02)				
25	909-99804	1	Guard (→ July'02)				
26	9-6001	4	Screw (M6x16)				
27	4-6001	8	Washer (M6)				

Motor Assembly (→ Apr'06)

9-03

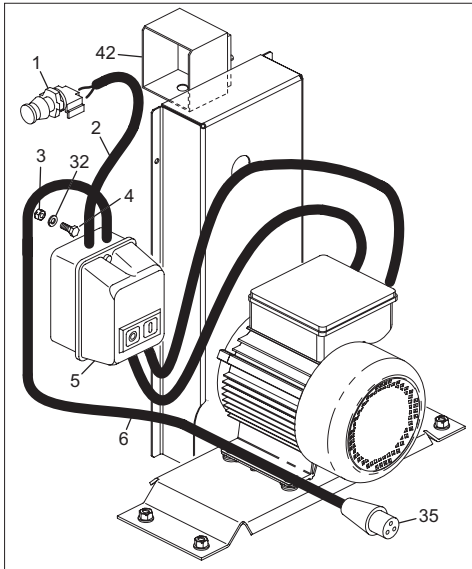

Item 42, should only be fitted by a qualified electrician.

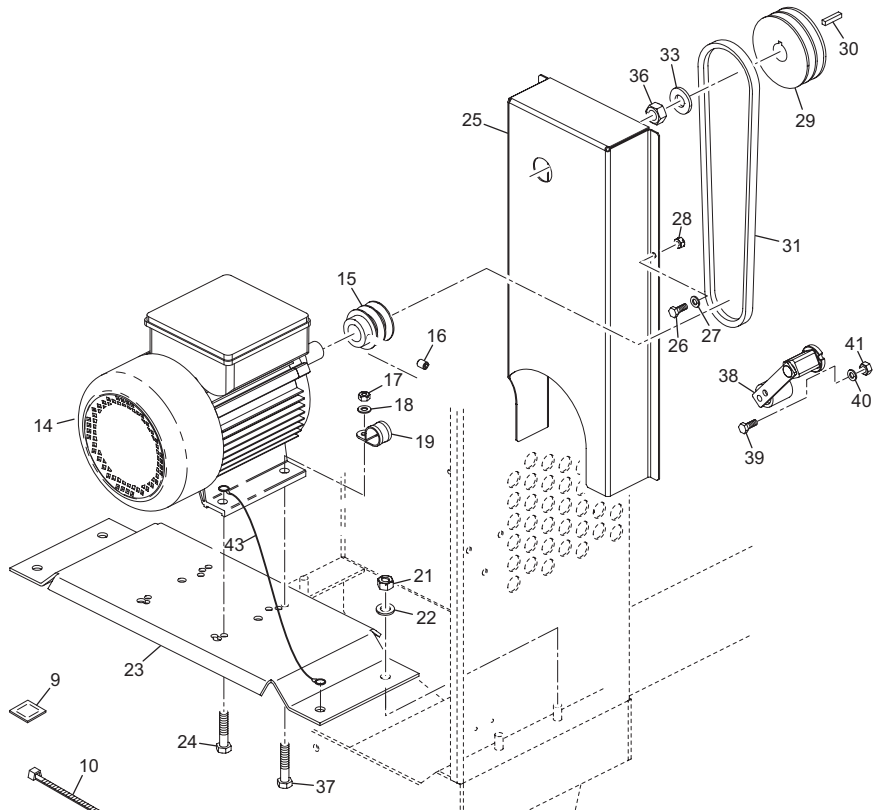
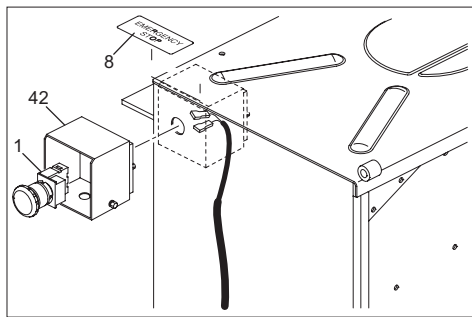

(CORRECT AT 03/06)

Motor Assembly (→ Apr'06)

9-03

1	70-0049	1	Switch Emergency Stop	28	8-6002	4	Nut (M6)
2	71-0251	1	Harness Emergency Stop	29	909-99964	1	Pulley
3	8-4004	2	Nut (M4)	30	909-99968	1	Key
4	9-4001	2	Bolt (M4x12)	31	21-0111	2	Belt (A38)
5	908-22000	1	Switchbox (110V)	32	4-4001	2	Washer
5A	908-20000	1	Switchbox (415V)	33	4-1602	1	Washer (M16)
5B	70-0240	1	Switchbox (230V)	35	918-30100	1	Plug (110V 32 amp)
6	71-0160	1	Harness Power (c/w 110V 32Amp Plug)	35A	70-0189	1	Plug (415V 32 amp)
6A	71-0165	1	Harness Power (c/w 415V 32Amp Plug)	35B	918-28500	1	Plug (240V 16 amp)
6B	71-0252	1	Harness Power (c/w 230V 16Amp Plug)	36	8-16002	1	Nut (M16)
8	900-11600	1	Decal Emergency Stop	38	909-99999	1	Jockey (Belt Tensioner)
9	900-99903	A/R	Pad	39	7-5020	1	Screw (M5x10)
10	1-0005	A/R	Cable Tie	40	8-5002	1	Nut (M5)
14	20-0078	1	Motor (110V)	41	4-5002	1	Washer (M5)
14A	20-0079	1	Motor (240V)	42	909-20100	1	Emergency Stop Cover Kit
14B	908-19900	1	Motor (415V)	43	71-0249	1	Earth Cable
15	908-14800	1	Pulley	-	800-21513	1	Decal Motor Maintenance
16	7-8006	1	Screw (M8x10)	-	800-21533	1	Decal Motor Start Up
17	8-10001	4	Nut (M10)	-	800-99916	1	Decal Motor Noise
18	4-1005	8	Washer (M10)				
19	900-10200	1	P-Clip				
20	4-8008	24	Washer (M8)				
21	8-12001	4	Nut (M12)				
22	4-12004	4	Washer (M12)				
23	909-99937	1	Motor Deck				
24	7-10005	4	Bolt (M10x25)				
25	909-99804	1	Guard				
26	9-6001	4	Screw (M6x16)				
27	4-6001	8	Washer (M6)				

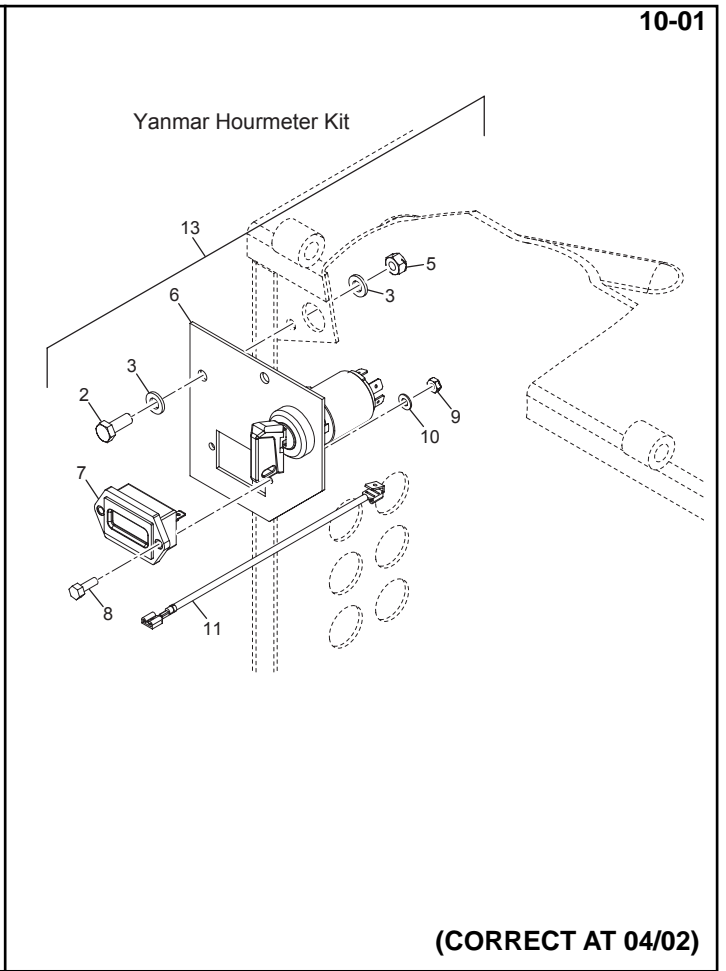
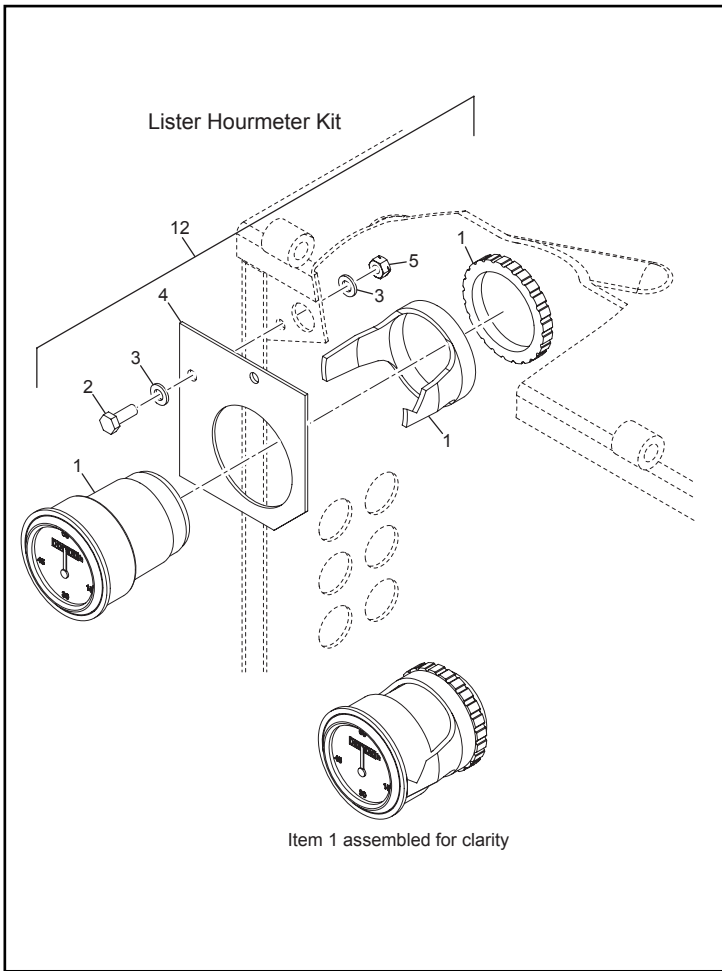

(CORRECT AT 04/02)

Hourmeter Assembly (Lister & Yanmar)

- | | | | | |
|----|------------------|---|-------|-----------------------------|
| 1 | 70-0039..... | 1 | | Engine Hour Meter (Lister) |
| 2 | 9-6001..... | 2 | | Bolt M6 x 16 Hex BZP |
| 3 | 4-6001..... | 4 | | Washer M6 Form A BZP |
| 4 | 909-99944..... | 1 | | Plate Lister Hourmeter |
| 5 | 8-6002..... | 2 | | Nut M6 BINX BZP |
| 6 | 909-99945..... | 1 | | Plate Yanmar Hourmeter |
| 7 | 100-02400..... | 1 | | Engine Hour Meter (Yanmar) |
| 8 | 9-4001..... | 2 | | Bolt M4 x 12 |
| 9 | 8-4004..... | 2 | | Nut M4 |
| 10 | 4-4001..... | 2 | | Washer M4 |
| 11 | 71-0171..... | 2 | | Harness Hour Meter (Yanmar) |
| 12 | OPM/04/DIO | 1 | | Hourmeter Kit (Lister) |
| 13 | OPM/05/DIO | 1 | | Hourmeter Kit (Yanmar) |



No.1 for Light Construction Equipment

www.BelleGroup.com

Belle Group Head Office
Sheen, nr. Buxton
Derbyshire. SK17 OEU GB.
Tel: +44 (0)1298 84000
Fax: +44 (0)1298 84722
email: sales@belle-group.co.uk

Belle Group France
70, av du Général de Gaulle
94022 Creteil, Cedex.
FRANCE
Tel: +33 (0) 1 49 81 68 32
Fax: +33 (0) 1 43 39 94 40
Ventes : 0800 902 461
SAV : 0800 905 336
SAV Fax : 0800 909 895

Belle Equipos SL
Calle Doctor Calero Cial 19,
Local 22, 28220 Majadahonda
Madrid, Spain
Tel: +34 (0) 91 636 2043
Fax: +34 (0) 91 634 1535
email: belleequipos@belleequipos.com

Belle Group Deutschland
Husumer Straße 45 a,
D-33729,
Bielefeld
Deutschland
Tel : +49(0) 5217 707505
Fax : +49 (0) 5217 707506
Sales: 0800 1808069
Spares: 0800 1816673

Belle Poland sp. z.o.o.
96-200 Rawa Mazowiecka
Ul. Mszczonowska 36,
Polska
Tel: +48 (0) 46 8144091
Fax: +48 (0) 46 8144700

Belle Group Portugal
Rua Laura Alves, 225, 2º F
2775-116 Parede
Portugal
Tel: +35 1 (21) 453 59 91
Fax: +35 1 (21) 453 59 91

Belle Group Netherlands
Tel: 0800 249861

Belle Group Belguim
Tel: 0800 80295

Belle Group Austria
Tel: 0800 291544

Belle Group Russia
64 Nevsky pr.
St, Petersburg
Russia
Tel : +7(812)314-81-34
Moscow : +7(495)589-64-32

Belle Group South East Asia
21, Jalan Ara AD 7/3B,
Pandar Sri Damansara
S2200 Kuala Lumpur, Malaysia
Tel: +60 (0) 3 62721678
+60 (0) 3 6272 9308
Fax: +60 (0) 3 6272 9528

Belle Group (GB), Shanghai Office
Room 213, Zhonghuang Building,
1007 Zhongshan Nan Er Road,
Xuhui, Shanghai 200030 China
Tel: 00 - 86 - 21 - 5461 5228
Mobile: 00 - 86 - 133 8172 2653
Fax: 00 - 86 - 21 - 5461 5369
email: morgan.liu@bellegroup.com.cn

Belle Group Inc
3959 Electric Rd
Roanoke
Suite 360
VA 24018. USA.
Tel: +1.540.345.5090
Fax: +1.540.345.5091
Toll free 866 540 5090
e-mail: sales@bellegroup.net



Belle Group World Parts Centre
Unit 5, Bode Business Park
Ball Haye Green,
Leek,
Staffordshire,
ST13 8BW
Tel: 44+ 1538 380000
Fax: 44+ 1538 380038

www.BelleGroup.com

No.1 for Light Construction Equipment

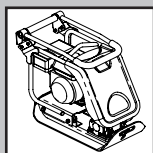

COMPACTING...

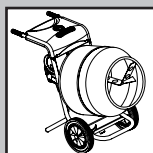

MIXING...

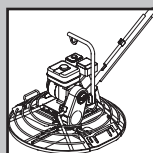

CONCRETING...

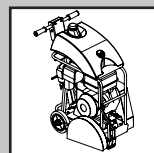

CUTTING...

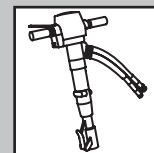

BREAKING...

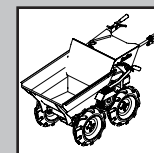

MOVING